

TW Series

Water to Water



BOSCH

Installation, Operation and Maintenance Manual

TABLE OF CONTENTS

Key to Symbols	3	Auto Changeover Mode.....	17
Safety Warnings	3	Unit Protection.....	17
Model Nomenclature	4	Manual Lockout	18
Standard TW package	5	Lead-Lag.....	18
General Description	5	Pump Cycling.....	18
Moving and Storage	5	Operating Instructions	18
Initial Inspection	5	User Interface.....	18
Location	5	UP Button.....	18
Installation	5	Down Button.....	18
Piping	6	LED Indicators.....	19
Electrical	6	User Adjustable Settings Chart	19
Safety Devices and the UPM Controller	7	Setting up the controller	19
Options	9	Initial Configuration	20
Heat Recovery Package (HRP)	9	Unit Check-out sheet	21
DPS Water Flow Proving	9	Troubleshooting	22
Pump Relay.....	9	Unit Troubleshooting.....	22
Comfort Alert Module	9	Confort Alert Module-Flash Codes.....	23
Heat Recovery Package	10	HRP Troubleshooting.....	24
Water Tank Preparation	10	Unit Lockouts	24
HR Water Piping	10	Electrical Data Table	25
Water Tank Refill.....	10	UPM Board LED Indicators	25
Initial Start-Up.....	10	Water Quality Table	26
Sequence Of Operation	11	Wiring Diagrams	27
Cooling Mode	11	Dimensional Drawings	33
Heating Mode.....	11	Terminology	36
Sequence Of Operation Flow.....	12		
Application Considerations	13		
Well Water Systems	13		
Cooling Tower/Boiler Systems	13		
Geothermal Systems	14		
System Checkout	15		
Considerations.....	15		
Unit Start-Up	16		
Maintenance	16		
Decommissioning	16		
Water To Water Unit Controller	16		
Features.....	16		
Unit Sensors	16		
Water Sensor.....	16		
Changeover Sensor.....	16		
Modes Of Operation	16		
Off Mode.....	16		
Heating Mode.....	16		
Cooling Mode.....	17		

KEY TO SYMBOLS

Warnings



Warnings in this document are identified by a warning triangle printed against a grey background. Keywords at the start of the warning indicate the type and seriousness of the ensuing risk if measures to prevent the risk are not taken.

The following keywords are defined and can be used in this document:

- **NOTICE** indicates a situation that could result in damage to property or equipment.
- **CAUTION** indicates a situation that could result in minor to medium injury.
- **WARNING** indicates a situation that could result in severe injury or death.
- **DANGER** indicates a situation that will result in severe injury or death.

Important Information



This symbol indicates important information where there is no risk to property or people.

SAFETY WARNINGS



WARNING: Installation and servicing of this equipment can be hazardous due to system pressure and electrical components. Only trained and qualified personnel should install, repair, or service the equipment.



DANGER: Before performing service or maintenance operations on the system, turn off main power to the unit. **Electrical shock could cause personal injury or death.**



WARNING: When working on equipment, always observe precautions described in the literature, tags, and labels attached to the unit. Follow all safety codes. Wear safety glasses and work gloves. Use a quenching cloth for brazing, and place a fire extinguisher close to the work area.

NOTICE: All refrigerant discharged from this unit must be recovered **WITHOUT EXCEPTION**. Technicians must follow industry accepted guidelines and all local, state, and federal statutes for the recovery and disposal of refrigerants. If a compressor is removed from this unit, refrigerant circuit oil will remain in the compressor. To avoid leakage of compressor oil, refrigerant lines of the compressor must be sealed after it is removed.

NOTICE: To avoid equipment damage, DO NOT use these units as a source of heating or cooling during the construction process. Doing so may affect the unit's warranty. The mechanical components and filters will quickly become clogged with construction dirt and debris, which may cause system damage.

NOTICE: To avoid the release of refrigerant into the atmosphere, the refrigerant circuit of this unit must be serviced only by technicians who meet local, state, and federal proficiency requirements.

STANDARD TW PACKAGE

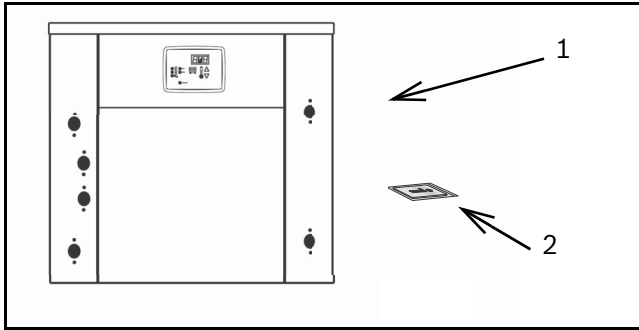

Figure # 1

- [1] TW Series Water-to-Water
- [2] Installation and Operation Manual

General Description

TW Series Water-to-Water Heat Pumps provide the best combination of performance and efficiency available. All units are performance certified to American Heating and Refrigeration Institute (AHRI) ISO Standard 13256-2. All TW Water-to-Water Heat Pumps conform to UL1995 standard and are certified to CAN/CSA C22.2 No 236 by Intertek-ETL. The Water-to-Water Heat Pumps are designed to operate with entering fluid temperature source between 30°F to 90°F in the heating mode and between 50°F to 110°F in the cooling mode on the source side



Heat Pump operating under extreme conditions will have limitation on fluid flow rates and/or temperatures.



50°F Minimum Entering Water Temperature (EWT) is recommended for well water applications with sufficient water flow to prevent freezing. Antifreeze solution is required for all closed loop applications. Cooling Tower/Boiler and Geothermal applications should have sufficient antifreeze solution to protect against extreme conditions and equipment failure. Frozen water coils are not covered under warranty. Other equivalent methods of temperature control are acceptable.

MOVING AND STORAGE

If the equipment is not needed for immediate installation upon its arrival at the job site, it should be left in its shipping carton and stored in a clean, dry area. Units must only be stored or moved in the normal upright position as indicated by the “UP” arrows on each carton at all times.



WARNING: For Storage if unit stacking is required, stack unit as follows:

Do not stack units larger than 6 tons. For units less than 6 tons, no more than three high

Initial Inspection

Be certain to inspect all cartons or crates on each unit as received at the job site before signing the freight bill. Verify that all items have been received and that there are no visible damages; note any shortages or damages on all copies of the freight bill. In the event of damage or shortage, remember that the purchaser is responsible for filing the necessary claims with the carrier. Concealed damages not discovered until after removing the units from the packaging must be reported to the carrier within 24 hours of receipt.

Location

Locate the unit in an indoor area that allows easy access to the panels, and has enough room for service personnel to perform maintenance or repair. Provide sufficient room to make fluid and electrical connection(s).

NOTICE: These units are not approved for outdoor installation; therefore, they must be installed within a conditioned space inside the structure. Do not locate in areas that are subject to freezing.

INSTALLATION

The TW series unit should be mounted level on a vibration absorbing pad slightly larger than the base to minimize vibration transmission to the building structure, It is not necessary to anchor the unit to the floor.(Figure #2).

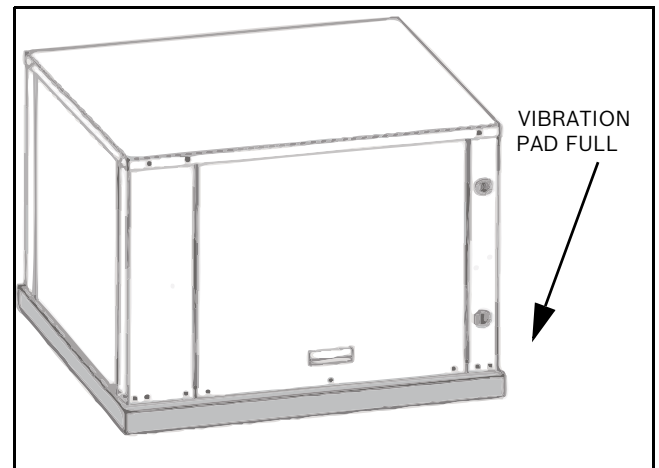

Figure # 2

PIPING

Supply and return piping must be as large as the unit connections on the heat pump (larger on long runs).

NOTICE: Never use flexible hoses of a smaller inside diameter than that of the fluid connections on the unit.

TW units are supplied with either a copper or optional cupro-nickel Water to refrigerant Heat Exchanger. Copper is adequate for ground water that is not high in mineral content.



Proper testing is recommended to assure the well water quality is suitable for use with water source equipment. When in doubt, use cupro-nickel. (See Water Quality Table on page #28)

In conditions anticipating moderate scale formation or in brackish water a cupro-nickel heat exchanger is recommended.

Both the supply and discharge water lines will sweat if subjected to low water temperature. These lines should be insulated to prevent damage from condensation. All manual flow valves used in the system must be ball valves. Globe and gate valves must not be used due to high pressure drop and poor throttling characteristics.

NOTICE: Never exceed the recommended water flow rates as serious damage or erosion of the water-to-refrigerant heat exchanger could occur.

Always check carefully for water leaks and repair appropriately. Units are equipped with female pipe thread fittings. Consult Unit Dimensional Drawings.



Teflon tape sealer should be used when connecting water piping connections to the units to insure against leaks and possible heat exchanger fouling.

NOTICE: Do not overtighten the connections.

Flexible hoses should be used between the unit and the rigid system to avoid possible vibration. Ball valves should be installed in the supply and return lines for unit isolation and unit water flow balancing. (See Water Quality Table on Page#26)

ELECTRICAL

Refer to electrical component box layout. (Figure #3)

NOTICE: Field wiring must comply with local and national electric codes.



WARNING: Power to the unit must be within the operating voltage range indicated on the unit nameplate or on the performance data sheet.



WARNING: Operation of unit on improper line voltage or with excessive phase imbalance will be hazardous to the unit, constitutes abuse and may void the warranty.

Properly sized fuses or HACR circuit breakers must be installed for branch circuit protection. See unit nameplate for maximum fuse or breaker size.

The unit is provided with a concentric knock-out for attaching common trade sizes of conduit, route power supply wiring through this opening. Always connect the ground lead to the grounding lug provided in the control box and power leads to the line side of compressor contactor as indicated on the wiring diagram (Figures on Pg#27 To 34).

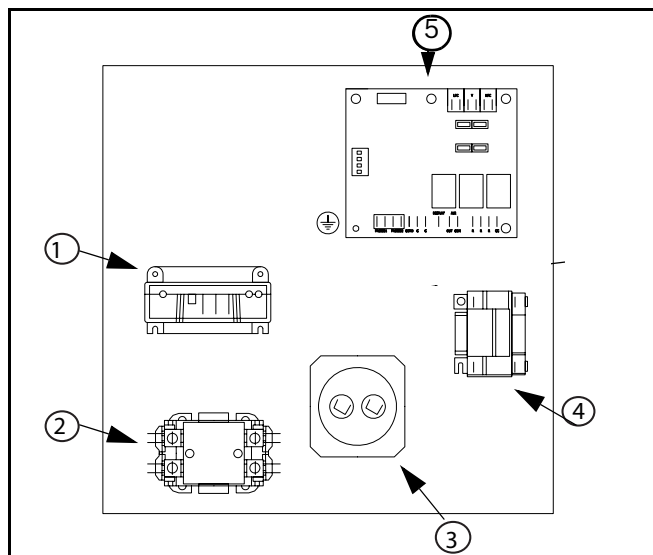

Figure # 3

- [1] Comfort Alert Module (Option)
- [2] Compressor contactor
- [3] Capacitor
- [4] Auxiliary Relay (DP/DT)
- [5] Unit Protection Module (UPM)(CS Option)

Safety Devices and the UPM Controller

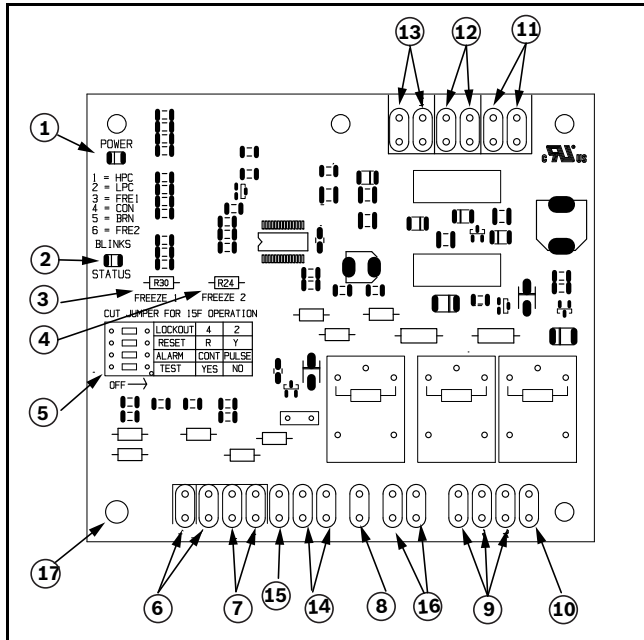

Figure # 4

- [1] Board Power Indicator
- [2] UPM Status LED Indicator
- [3] Water Source Coil Freeze Protection Temperature Selection [R30]
- [4] Load Water Coil Freeze Protection Temperature Selection [R24]
- [5] UPM Board Settings
- [6] Source Coax Freeze Connection (Freeze 1)
- [7] Load Coax Freeze Connection (Freeze 2)
- [8] LCD Unit Display Connection
- [9] 24VAC Power Input
- [10] Compressor Contact Output
- [11] High Pressure Switch Connection
- [12] Call for Compressor Y1
- [13] Low Pressure Switch Connection
- [14] 24VAC Power Common
- [15] Condensate overflow Sensor (not applicable on TW)
- [16] Dry Contact
- [17] UPM Ground Standoff

i If the unit is being connected to a thermostat with a malfunction light, this connection is made at the unit malfunction output or relay. Refer to Figure #4.

i If the thermostat is provided with a malfunction light powered off of the common (C) side of the transformer, a jumper between “R” and “COM” terminal of “ALR” contacts must be made.

i If the thermostat is provided with a malfunction light powered off of the hot (R) side of the transformer, then the thermostat malfunction light connection should be connected directly to the (ALR) contact on the unit’s UPM board.

The TW Series has an optional factory installed Unit Protection Module (UPM) that controls the compressor operation and monitors the safety controls that protect the unit.

Safety controls include the following:

- High pressure switch located in the refrigerant discharge line and wired across the HPC terminals on the UPM.
- Low pressure switch located in the unit refrigerant suction line and wired across terminals LPC1 and LPC2 on the UPM.
- Water side freeze protection sensor, mounted close to condensing water coil, monitors refrigerant temperature between condensing water coil and thermal expansion valve. If temperature drops below or remains at freeze limit trip for 30 seconds, the controller will shut down the compressor and enter into a soft lockout condition. The default freeze limit trip is 26°F, however this can be changed to 15°F by cutting the R30 or Freeze1 resistor located on top of DIP switch SW1 (Refer to Figure #4, item [3] for resistor location), Refer to Figure #5 for sensor location

i UPM Board Dry Contacts are Normally Open (NO)

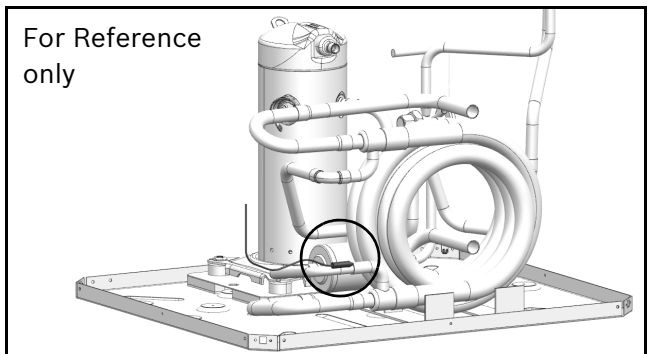

Figure # 5





For Reference only

NOTICE: If unit is employing a fresh water system (no anti-freeze protection), it is extremely important to have the Freeze1 R30 resistor set to 26°F in order to shut down the unit at the appropriate leaving water temperature and protect your heat pump from freezing if a freeze sensor is included.

UPM Board Factory Default Settings

TEMP	26°F
LOCKOUT	2
RESET	Y
ALARM	PULSE
TEST	NO

UPM DIP SWITCH DEFAULT POSITION

	lockout	4	2
	reset	R	Y
	alarm	Cont	pulse
	test	yes	no

The UPM Board includes the following features:

- **ANTI-SHORT CYCLE TIMER:** 5 minute delay on break timer to prevent compressor short cycling.
- **RANDOM START:** Each controller has an unique random start delay ranging from 270 to 300 seconds on initial power up to reduce the chance of multiple unit simultaneously starting at the same time after power up or after a power interruption, thus avoiding creating large electrical spike.
- **LOW PRESSURE BYPASS TIMER:** If the compressor is running and the low pressure switch opens, the controller will keep the compressor ON for 120 seconds. After 2 minutes if the low pressure switch remains open, the controllers will shut down the compressor and enter a soft lockout. The compressor will not be energized until the low pressure switch closes and the anti-short cycle time delay expires. If the low pressure switch opens 2-4 times in 1 hour, the unit will enter a hard lockout. In order to exit hard lockout power to the unit would need to be reset.
- **BROWNOUT/SURGE/POWER INTERRUPTION PROTECTION:** The brownout protection in the UPM board will shut down the compressor if the incoming power falls below 18 VAC. The compressor will remain OFF until the voltage is above 18 VAC and ANTI-SHORT CYCLE TIMER (300 seconds) times out. The unit will not go into a hard lockout.

- **MALFUNCTION OUTPUT:** Alarm output is Normally Open (NO) dry contact. If pulse is selected the alarm output will be pulsed. The fault output will depend on the dip switch setting for "ALARM". If it is set to "CONST", a constant signal will be produced to indicate a fault has occurred and the unit requires inspection to determine the type of fault. If it is set to "PULSE", a pulse signal is produced and a fault code is detected by a remote device indicating the fault. See L.E.D Fault Indication below for blink code explanation. The remote device must have a malfunction detection capability when the UPM board is set to "PULSE".



If 24 VAC output is needed, R must be wired to ALR-COM terminal; 24 VAC will be available on the ALR-OUT terminal when the unit is in the alarm condition.

- **DISPLAY OUTPUT:** The Display output is a pulse output connected to the Unit Diagnostic Display (UDD) and it pulses 24VAC when the unit is in an lockout alarm condition.
- **TEST DIP SWITCH:** A test dip switch is provided to reduce all time delays settings to 10 seconds during troubleshooting or verification of unit operation.

NOTICE: Operation of unit in test mode can lead to accelerated wear and premature failure of components. The "TEST" switch must be set back to "NO" after troubleshooting/servicing.

- **FREEZE SENSOR:** The default setting for the freeze limit trip is 26°F (sensor number 1); however this can be changed to 15°F by cutting the R24 resistor located on top of the DIP switch SW1. Since freeze sensor 2 is dedicated to monitor the load side coil it is recommended to leave the factory default setting on the board. The UPM controller will constantly monitor the refrigerant temperature with the sensor mounted close to the condensing water coil between the thermal expansion valve and water coil. If temperature drops below or remains at the freeze limit trip for 30 seconds, the controller will shut the compressor down and enter into a soft lockout condition. Both the status LED and the Alarm contact will be active. The LED will flash (three (3) times) the code associated with this alarm condition. If this alarm occurs 2 times (or 4 if Dip switch is set to 4) within an hour the UPM controller will enter into a hard lockout condition. It will constantly monitor the refrigerant temperature with the sensor mounted close to the evaporator between the thermal expansion valve and

evaporator coil as shown in Figure #5. If temperature drops below or remains at the freeze limit trip for 30 seconds, the controller will shut the compressor down and enter into a soft lockout condition. Both the status LED and the Alarm contact will be active. The LED will flash (six (6) times) the code associated with this alarm condition. If this alarm occurs 2 times (or 4 if Dip switch is set to 4) within an hour the controller will enter into a hard lockout condition.

NOTICE: Freeze sensor will not guard against the loss of water. Flow switch is recommended to prevent unit from running if water flow is lost or reduced.

- **INTELLIGENT RESET:** If a fault condition is initiated, the 5 minute delay on break time period is initiated and the unit will restart after these delays expire. During this period the fault LED will indicate the cause of the fault. If the fault condition still exists or occurs 2 or 4 times (depending on 2 or 4 setting for Lockout dip switch) before 60 minutes, the unit will go into a hard lockout and requires a manual lockout reset.
- **LOCKOUT RESET:** A hard lockout can be reset by turning the unit thermostat off and then back on when the “RESET” dip switch is set to “Y” or by shutting off unit power at the circuit breaker when the “RESET” dip switch is set to “R”.

OPTIONS

Number of factory installed options are available on TW Series of Heat Pumps. The following details the purpose, function and components of each option.

Heat Recovery Package (HRP)

The heat recovery package is a factory installed option on TW series heat pumps. The HRP can be used to heat potable water during unit operation using waste heat from the compressor discharge gas. In some cases the HRP can provide most or all of the hot water requirements for a typical home.

The HRP consists of three major components:

- Double wall, vented refrigerant to water heat exchanger
- Circulating pump
- Control circuit

The heat exchanger is rated for use with potable water and is acceptable for use as a domestic water heating device in most building codes.

The pump circulates water between the domestic hot water tank and HRP heat exchanger in the Heat Pump. The control circuit ensures that the HRP only operates when there is available heat from the compressor and when the water is within a safe temperature range of below 140 deg F.

When the heat pump compressor operates, the HRP will monitor the temperature of the discharge gas from the compressor. Once discharge gas is hot enough to provide useful heat to the domestic water tank, the circulating pump will be enabled, drawing water from the tank, through the HRP heat exchanger and then depositing the heated water back into the tank. If the water temperature reaches 140 deg F, the circulating pump is disabled to prevent over heating of the domestic water. The HRP is provided with an on/off switch in case the end user desires that the HRP be inactivated (typically during the winter months when space heating is most important).

NOTICE: If heat recovery unit is installed in an area where freezing may occur, the unit must be drained during winter months to prevent heat exchanger damage. Heat exchanger ruptures that occur due to freezing will void the heat recovery package warranty along with the heat pump warranty.

DPS Water Flow Proving

The DPS water flow proving switch is a factory installed option available for the WW series. The DPS prevents compressor operation if there is inadequate water flow through the water to refrigerant heat exchanger in the heat pump.

The DPS operates by monitoring the water side pressure drop across the water to refrigerant heat exchanger. When the pressure drop between the water in and water out lines reaches a pre-set value, compressor operation is enabled.

Pump Relay

The factory installed pump relay can be used to energize a supply pump or solenoid valve when there is a call for compressor operation. This relay can be used to switch either high or low voltage power.

Comfort Alert Module

The Comfort Alert diagnostics module (CADM) is a breakthrough innovation for troubleshooting heat pump system failures. (Figure #6)



Figure # 6

By monitoring and analyzing data from the compressor and the thermostat demand, the module can accurately detect the cause of electrical and system related failures without any sensors. A flashing LED indicator communicates the ALERT code and guides the service technician more quickly and accurately to the root cause of a problem.



This module does not provide safety protection! The Comfort Alert module is a monitoring device and cannot shut down the compressor directly.

When an abnormal system condition occurs, the Comfort Alert module displays the appropriate ALERT and/or TRIP LED.

The yellow ALERT LED will flash a number of times consecutively, pause and then repeat the process.

To identify a Flash Code number, count the number of consecutive flashes.

Every time the module powers up, the last ALERT Flash Code that occurred prior to shut down is displayed for one minute. Heat Recovery Package

HEAT RECOVERY PACKAGE

Water Tank Preparation

1. Turn off electrical or fuel supply to the water heater.
2. Attach garden hose to water tank drain connection and run other end of hose out doors or to an open drain.
3. Close cold water inlet valve to water heater tank.
4. Drain tank by opening drain valve on the bottom of the tank, then open pressure relief valve or hot water faucet.
5. Once drained the tank should be flushed with cold water until the water leaving the drain hose is clear and free of sediment.
6. Close all valves and remove the drain hose.
7. Install HR water piping.



Concentric water fitting (p/n 8733907119) is recommended.
(See Figure # 7)

HR Water Piping

All hot water piping MUST be a minimum of 3/8t O.D. copper tube to a maximum distance of fifteen (15) feet. For distances beyond fifteen feet but not exceeding sixty (60) feet use 1/2" copper tube. Separately insulate all exposed surface of both connecting water lines with 3/8" wall closed cell insulation. Install isolation valves on supply and return to the heat recovery. (Figure # 7)

Water Tank Refill

1. Open the cold water supply to the tank.
2. Open a hot water faucet to vent air from the system until water flows from the faucet, then close.

3. Depress the hot water tank pressure relief valve handle to ensure there is no air remaining in the tank.
4. Carefully inspect all plumbing for water leaks. Correct as required.
5. Purge all air from HR by depressing the schrader valve on the HR Unit. Allow all air to bleed out until water appears at the valve.
6. Before restoring the power or fuel supply to the water heater, adjust the temperature setting on the tank thermostat(s) to ensure maximum utilization of the heat available from the refrigeration system and conserve the most energy. On tanks with both upper and lower elements and thermostats, the lower element should be turned down to 100° F, while the upper element should be adjusted to 120° F. Depending upon the specific needs of the customer, you may need to adjust the upper element differently. On tanks with a single thermostat lower the thermostat setting to 120° F or the "LOW" position. After thermostat adjustments are completed, replace access cover and restore electrical or fuel supply to water heater.

NOTICE: All piping from HRP to domestic water tank must be copper or any metal of stronger alloy.

Initial Start-Up

NOTICE: Make sure all valves in heat recovery water piping system are open.
NEVER OPERATE HR PUMP DRY.

1. Turn on the heat pump. The HR pump should not run if the compressor is not running
2. Turn HR switch to the "ON" position. The pump will operate if entering water temperature to HR is below 120° F.
3. The temperature difference between the water entering and leaving the heat recovery should be 5° to 15° F.
4. Allow the unit to operate for 20 to 30 minutes to ensure it is functioning properly. The pump should shut off when the water temperature entering the heat recovery reaches 120°F.

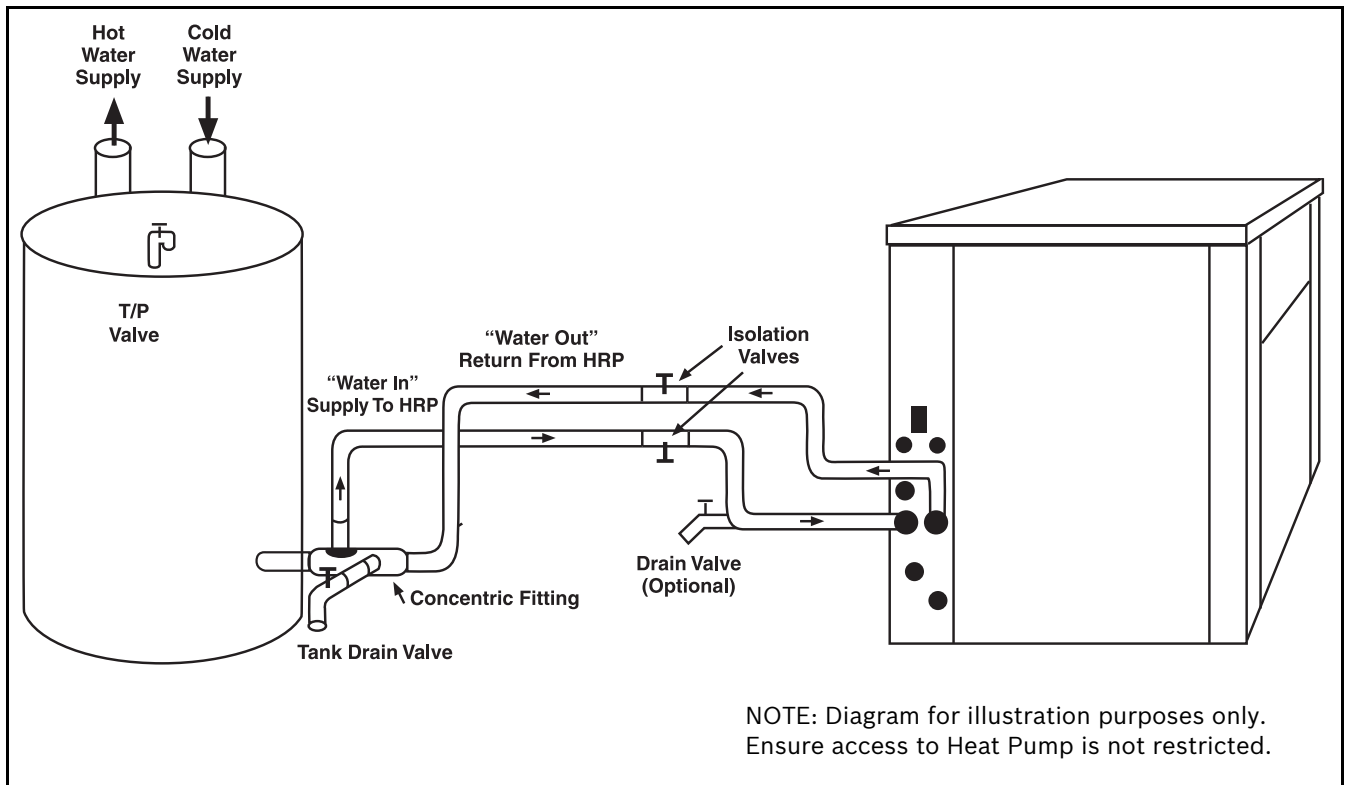

Figure # 7

SEQUENCE OF OPERATION

Cooling Mode

Energizing the "O" terminal energizes the unit reversing valve thus placing the unit into cooling mode. T

When the thermostat calls for first stage cooling (Y1) the loop pump or solenoid valve if present is energized and the first stage of compressor capacity starts.

When the thermostat calls for second stage cooling (Y2) the second stage (or full compressor capacity) is initiated. Once the thermostat is satisfied, the compressor shuts down accordingly

Heating Mode

The first two stages of heating (Y1 & Y2) operate in the same manner as cooling, but with the reversing valve de-energized. Once the thermostat is satisfied, the compressor shuts down,

SEQUENCE OF OPERATION FLOW

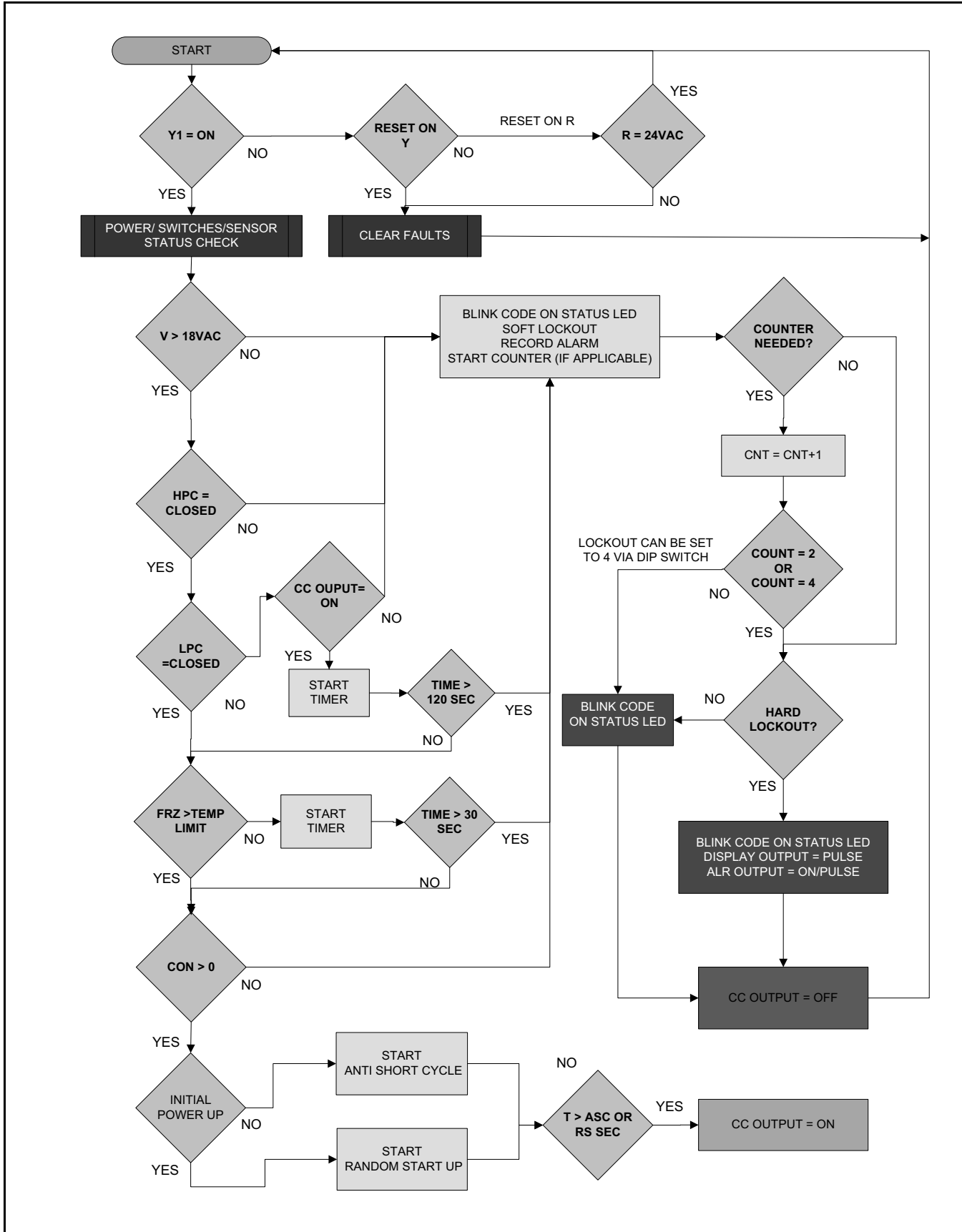

Figure # 8

APPLICATION CONSIDERATIONS

Well Water Systems

Copper is adequate for ground water that is not high in mineral content. Should your well driller express concern regarding the quality of the well water available or should any known hazards exist in your area, we recommend proper testing to assure the well water quality is suitable for use with water source equipment. In conditions anticipating moderate scale formation or in brackish water a cupro-nickel heat exchanger is recommended. In well water applications water pressure must always be maintained in the heat

exchanger. This can be accomplished with either control valve or a bladder type expansion tank. When using a single water well to supply both domestic water and the heat pump care must be taken to insure that the well can provide sufficient flow for both. In well water applications a slow closing solenoid valve must be used to prevent water hammer. Solenoid valves should be connected across Y1 and C1 on the interface board for all. Make sure that the VA draw of the valve does not exceed the contact rating of the thermostat. (Figure #9)

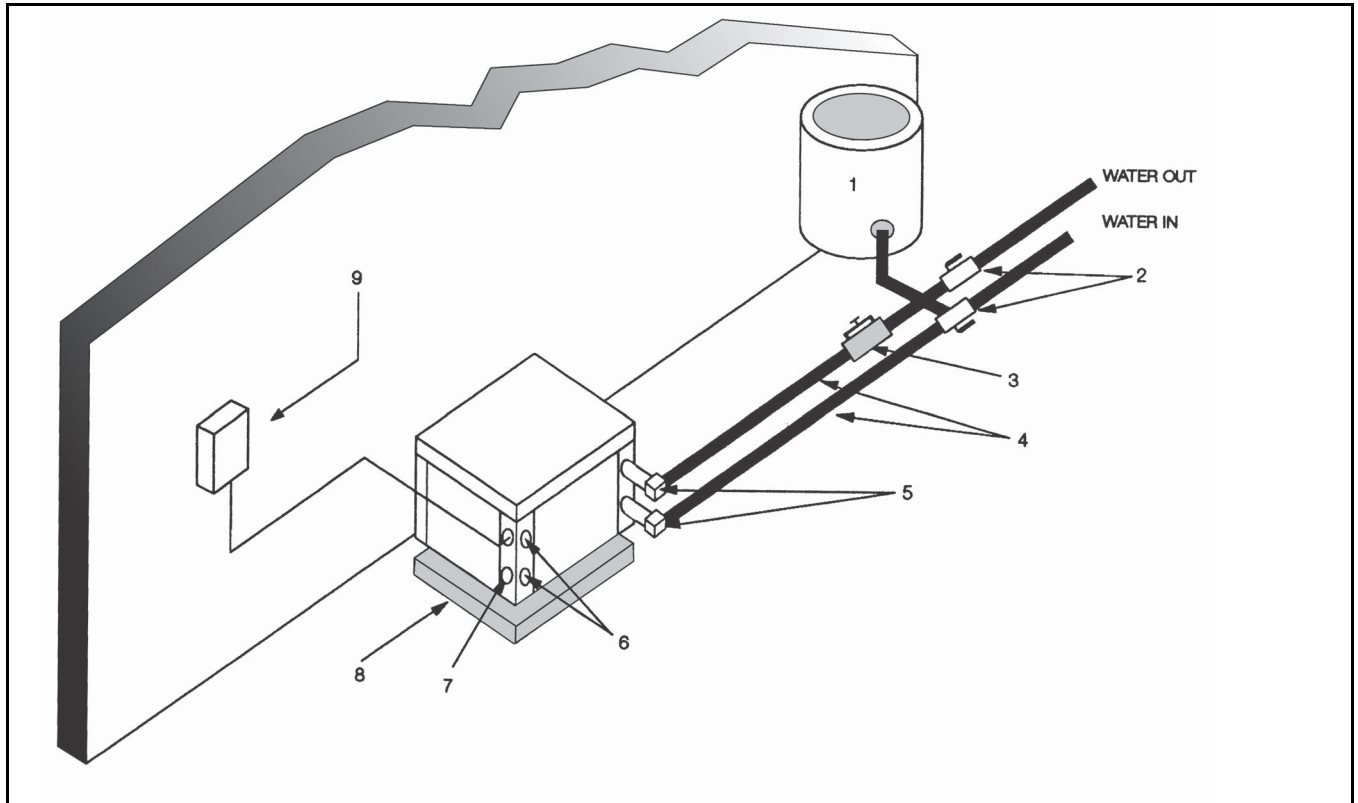

Figure # 9 Example System Set-up

- [1] Pressure Tank
- [2] Ball Valves
- [3] Solenoid Valve
- [4] Hose kit
- [5] P/T Kit
- [6] Load Side Connections
- [7] Low Voltage Control Connection
- [8] Vibration Pad
- [9] Line Voltage Control Connection

Cooling Tower/Boiler Systems

The cooling tower and boiler water loop temperature is usually maintained between 50° F to 100 ° F to assure adequate cooling and heating performance.

In the cooling mode, heat is rejected from the unit into the water loop. A cooling tower provides evaporative cooling to the loop water thus maintaining a constant supply temperature to the unit. When utilizing open cooling towers, chemical water treatment is mandatory to ensure the water is free from corrosive elements. A secondary heat exchanger (plate frame) between the unit and the open cooling tower may also be used.

It is imperative that all air be eliminated from the closed loop side of the heat exchanger to insure against fouling. In the heating mode, heat is absorbed from the water loop. A boiler can be utilized to maintain the loop at the desired temperature.

NOTICE: Water piping exposed to extreme low ambient temperatures is subject to freezing.



Teflon tape sealer should be used when connecting to the unit to insure against leaks and possible heat exchanger fouling.

Consult the specification sheets for piping sizes.



Do not overtighten the connections. Flexible hoses should be used between the unit and the rigid system to avoid possible vibration

Ball valves should be installed in the supply and return lines for unit isolation and unit water flow balancing. Pressure/temperature ports are recommended in both supply and return lines for system flow balancing. Water flow can be accurately set by measuring the water-to-refrigerant heat exchangers water side pressure drop. See specification sheets for water flow vs. pressure drop information.

No unit should be connected to the supply or return piping until the water system has been completely cleaned and flushed to remove any dirt, piping chips or other foreign material. Supply and return hoses should be connected together during this process to ensure the entire system is properly flushed. After the cleaning and flushing has taken place the unit may be connected to the water loop and should have all valves wide open.

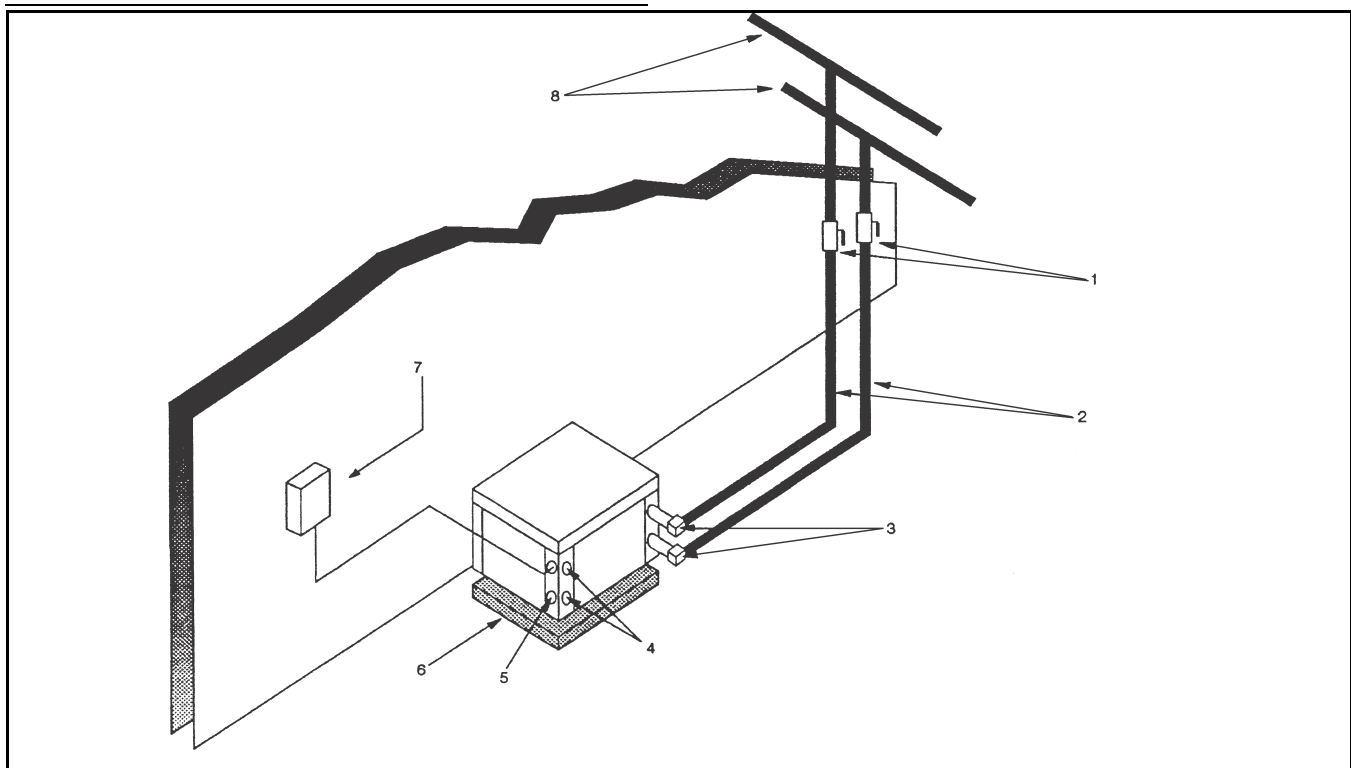

Figure # 10

1. Ball Valves.
2. Hose kits.
3. P/T Plugs
4. Load Side Connections.
5. Low Voltage Control Connections.
6. Vibration Pad.
7. Line Voltage Disconnect.
8. Supply and Return lines of central system.

Geothermal Systems

Closed loop and pond applications require specialized design knowledge. No attempt at these installations should be made unless the dealer has received specialized training. Utilizing the Ground Loop Pumping Package (GLP), makes the installation easy. Anti-freeze solutions are utilized when low evaporating conditions are expected to occur. Refer to the GLP installation manuals for more specific instructions. (Figure #11)

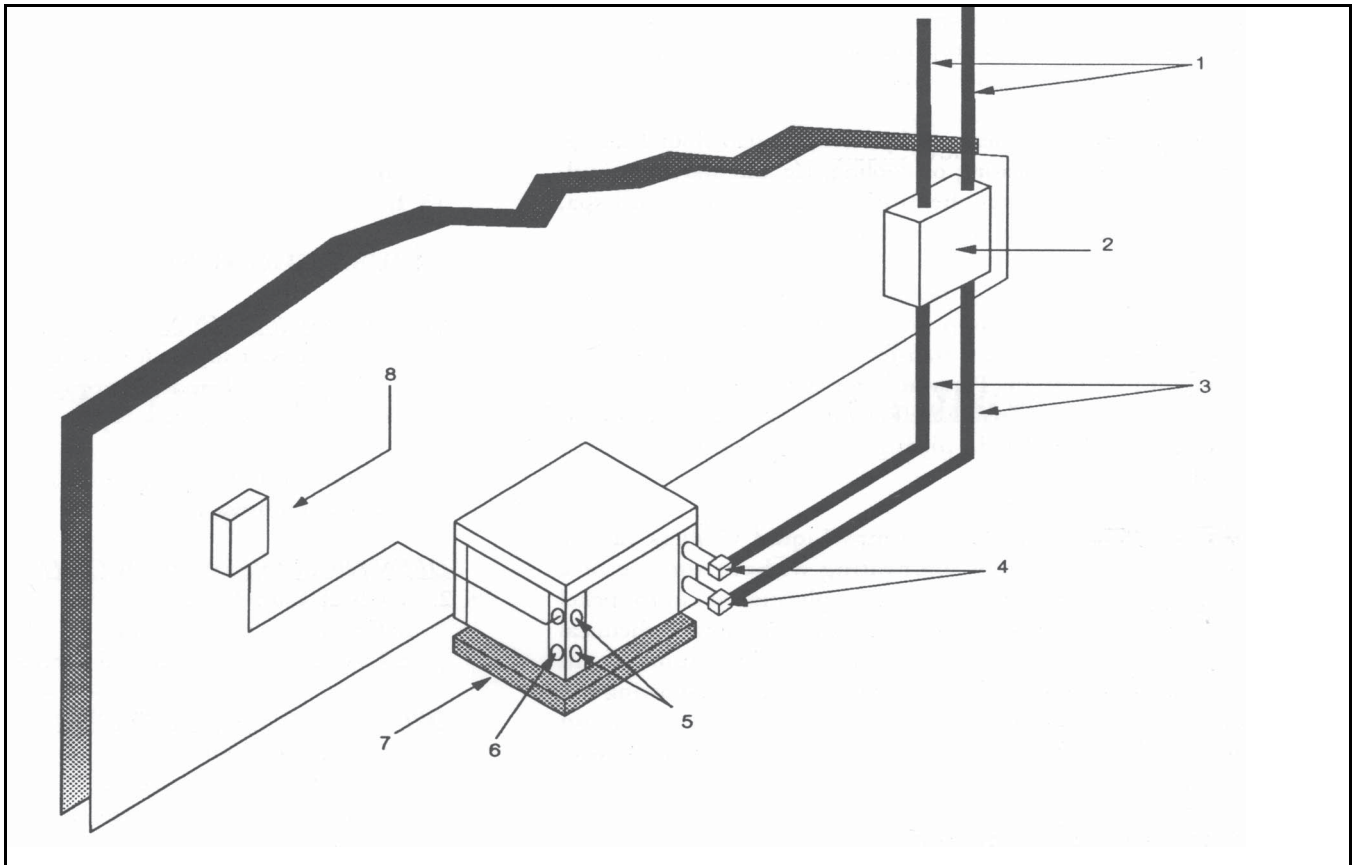

Figure # 11

- [1] Polybutylene or Polyethelene with insulation
- [2] Ground loop pumping package (GLP)
- [3] Ground loop connection kit.
- [4] P/T Plugs
- [5] Load side connection
- [6] low voltage control connection
- [7] Vibration Pad
- [8] Line Voltage disconnect

- 7. Verify that vibration isolation has been provided.
- 8. Unit is serviceable. Be certain that all access panels are secured in place.

Considerations:

- Always check incoming line voltage power supply and secondary control voltage for adequacy. Transformer primaries are dual tapped for 208 and 230 volts. Connect the appropriate tap to ensure a minimum of 18 volts secondary control voltage. 24 volts is ideal for best operation.
- Long length thermostat and control wiring leads may create voltage drop. Increase wire gauge or up-size transformers may be required to insure minimum secondary voltage supply.
- We recommends the following guidelines for wiring between a thermostat and the unit: 18 GA up to 60 foot, 16 GA up to 100 ft and 14 GA up to 140 ft.
- Do not apply additional controlled devices to the control circuit power supply without consulting the factory. Doing so may void equipment warranties.
- Check with all code authorities on installation criteria.

SYSTEM CHECKOUT

After completing the installation, and before energizing the unit, the following system checks should be made:

1. Verify that the supply voltage to the heat pump is in accordance with the nameplate ratings.
2. Make sure that all electrical connections are tight and secure.
3. Check the electrical fusing and wiring for the correct size.



DANGER: Ensure cabinet and Electrical Box are properly grounded.

4. Verify that the low voltage wiring between the thermostat and the unit is correct.
5. Verify that the water piping is complete and correct.
6. Check that the water flow is correct, and adjust if necessary.

UNIT START-UP

1. Set the thermostat to the highest setting.
2. Set the thermostat system switch to "COOL", . The reversing valve solenoid should energize. The compressor should not run.
3. Reduce the thermostat setting approximately 5 degrees below the room temperature.
4. Verify the heat pump is operating in the cooling mode.
5. Turn the thermostat system switch to the "OFF" position. The unit should stop running and the reversing valve should de energize.
6. Leave the unit off for approximately (5) minutes to allow for system equalization.
7. Turn the thermostat to the lowest setting.
8. Set the thermostat switch to "HEAT".
9. Increase the thermostat setting approximately 5 degrees above the room temperature.
10. Verify the heat pump is operating in the heating mode.
11. Set the thermostat to maintain the desired space temperature.
12. Check for vibrations, leaks, etc.

MAINTENANCE

An annual "checkup" is recommended by a licensed refrigeration mechanic. Recording the performance measurements of volts, amps, and water temperature differences (both heating and cooling) is recommended. This data should be compared to the information on the unit's data plate and the data taken at the original startup of the equipment.

INFORMATION ON DECOMMISSIONING

Only authorized technicians are allowed to decommission and dispose of equipment following applicable requirements and local codes.



WARNING: Decommissioning of this equipment can be hazardous due to system pressure and electrical components. Only trained and qualified personnel should install, repair, or service or decommission the equipment.

WATER TO WATER UNIT CONTROLLER

Bosch water heat pump controller offers a low cost, simple solution to the control of a water to water heat pump unit. The control is configurable to provide cooling only, heating only or auto change over control strategies based on the application of the unit in a given system.

Features:

- Selectable mode of operation. Cooling, Heating or Auto Changeover.
- Adjustable temperature differential for heating and cooling set point.

- Adjustable auto changeover set point with adjustable dead band setting.
- Intelligent auto reset of a fault condition avoids nuisance hard lockouts.
- LED display of control temperature and set points.
- F° or C° Display.
- 50/60 Hertz operation.
- Pump operation configurable for continuous or cycling operation with the compressor.
- Compressor lead-lag operation on units with dual compressors.
- Malfunction output and service LED can be set to steady or pulsing to indicate fault condition.
- Color LED's indication of mode of operation.
- Set point retention in non volatile memory in the event of a power failure.
- Five minute delay on break or power interruption for compressor short cycling protection.
- Brown out low voltage protection.

UNIT SENSORS

The unit controller is provided with two sensors:

Water sensor:

This sensor will control unit operation in the cooling or heating mode based on the water temperature on the load side. It may be field mounted for example on the return water line or in a water tank when provided with a field supplied inversion well. The location will depend on the specific requirements of the job.

Changeover Sensor

This sensor will put the unit in either the heating or cooling mode depending on the set point. It maybe mounted in a location that would be indicative if the unit should be in either the heating or cooling mode, for example outdoors.

The sensor may be located up to 1000 feet from the unit (additional field supplied wiring required).

MODES OF OPERATION

The controller will memorize the last mode used before power is removed and will run in that mode after is turned on. In all modes the control will display temperature degree differential setting for five seconds once it is powered and this setting for five seconds once it is powered and this settings may be adjusted during this time. Thereafter the display will switch to the monitored water temperature. When switching from one mode to another the set point (the decimal point is used to distinguish it from water temperature) for the new mode is displayed for 5 seconds and the monitored water temperature. During this time the set point may be adjusted.

Off Mode

In the OFF MODE all outputs are disabled and mode indication LED's will be off.

The control will first display temperature differential setting with the ability for the user to adjust it and then will display "OFF" and finally water temperature.

Heating Mode

When the unit is operated in the heating mode and the controlled water temperature is below the set point minus the differential setting is below the set point minus the differential setting, terminal Y1 will close and the unit will operate (first stage compressor in a two stage unit). When the set point is satisfied the compressor is turned off.

In a two stage unit after the first activation if the water temperature drops an additional two degrees below the set point, the second stage (terminal Y2) will be activated (if control is configured for both compressors). Both stages will be on until the set point is satisfied.

When the units runs after power is applied or the mode is changed from cooling to heating, if the fluid temperature is below set point and does not change for 3 minutes, the second stage of heating will be activated. This only applies for a two stage machine.

There will be 5 minutes delay on a break after the unit cycles off on temperature, a power interruption or because of a fault condition.

at any point in time the control will ignore a low pressure switch condition for 120 seconds before turning off the compressor.

Cooling Mode

When the unit is operated in the cooling mode and the leaving water temperature is above temperature set point plus the differential setting, terminals Y1 will close (first stage compressor of a two stage unit) and the unit will operate in the cooling mode. When the set point is satisfied the compressor is turned off. The reversing valve is always activated when the unit is in the cooling mode.

On two stage units, after first stage activation if water temperature increases two degrees above the set point, the second stage (terminal Y2) will be activated (if control is configured for both compressors). Both stages will remain on until the set point is satisfied.

when the unit runs after power is applied or the mode is changed from heating to cooling, if fluid temperature is above cooling point and does not change for 3 minutes, the second stage of cooling will be activated. this only applies for a two stage machine.

There will be 5 minute delay on break after the unit cycles off on temperature, a power interruption or because of a fault condition.

Auto Changeover Mode

The controller's auto change over mode control feature will switch from the heating mode to cooling mode and vice versa based on the setting of the change over sensor. There will be a dead-band where the control will not call for either heat or cool. The dead -band setting is adjustable in the configuration mode. When the auto changeover mode is selected the changeover set point will be displayed for 5 seconds, however this point is only adjustable when the controller is in the configuration mode. Once the controller has switched to

either heating or cooling mode, pressing the up or down buttons will display the set point for that particular mode.

When the reading from the changeover sensor is above the change over set point plus the dead-band setting, the unit will operate in the cooling mode and will maintain the cooling set point temperature. While in the cooling mode the user can adjust the cooling set point. Likewise when the change over sensor is below the changeover set point minus the dead-band setting, the unit will switch to the heating mode and will maintain the heating set point temperature. While in the heating mode the user can adjust the heating set point.

Once the reading from the sensor enters the dead-band zone it will terminate the call for cooling or heating even if the set points are not satisfied.

Mode switching will be HEAT – COOL – OFF in a closed loop. If the changeover sensor is shorted when the control is in Auto changeover mode then the control will switch to the OFF mode. If no sensor is connected the controller will indicate a sensor error code.

Unit Protection

The unit controller will protect the unit against a high or low pressure condition and brownout. To avoid nuisance lockouts an intelligent reset function is built into the controller to allow the unit to restart one time in the event of a fault condition. If a fault condition is initiated on any circuit the corresponding compressor will be turned off and the 5 minute delay on break time period timer is initiated. After the delay expires the unit will attempt to restart. If the fault condition still exists or reoccurs within the next 60 minutes, the unit will go into a hard lockout and requires a manual lockout reset. During this period the fault LED will indicate the cause of the fault. A 120 second time delay is built into the low pressure switch to avoid nuisance trips with low fluid temperatures.

While in a soft lockout condition the display will show the specific fault (for example LP1) and the "service" LED will turn on according to the malfunction mode. If the setting for malfunction mode is "steady," the service LED will turn and remain on. If the setting is "pulse," the service LED will blink according to the blink code as follows:

Brownout Protection

The control will disable all outputs if the supply voltage drops below 17 VAC. The outputs will be enabled if the supply voltage rises and remains above 17 VAC for the 5 minutes time delay. During that time control will display “bro.”

MANUAL LOCKOUT

Blink Code	Fault Condition
ONE BLINK	High pressure circuit 1
TWO BLINKS	Low pressure circuit 1
THREE BLINKS	high pressure circuit 2
FOUR BLINKS	Low pressure circuit 2

The unit or refrigeration circuit will go into a manual lockout if the HPS or LPS opens (LPS open more than 120 seconds each time) twice within one hour. During manual lockout the compressor(s) is turned off and locked out and the display will show the fault (for example LP1) and the “service” LED “malfunction” output will either be steady or blink according to the malfunction mode as described above.

If selection for compressor is “Du” (see configuration) and one compressor has locked out, the control will switch the call to the other compressor. If compressor setting is “Si”, the control shall not switch the call to the other compressor



To reset a unit after a hard lockout the user needs to recycle power or switch the controller to the OFF mode.

Lead-Lag (only for TW122 units)

The Controller has the capability to lead-lag compressors on a dual compressor unit.

The lead-lag between the compressors is active only when both compressors are in use (and the compressor setting is “Du”).

When the setting for lead-lag is other than 00, compressor setting is “Du” and one compressor has locked out; control will switch the call to the other compressor and stop the timing for lead-lag. The lead lag setting remains in the memory.

If control has called for the second stage three times in a row, and compressor setting is “Du”; regardless of the lead-lag setting control will switch the call to the other compressor. The lead-lag timer is reset and the lead-lag setting still applies.

Pump cycling

When ordered with the optional pump relay the controller will cycle either the load, source or both pumps with the compressor operation. Please see the typical wiring diagram for details.

OPERATING INSTRUCTIONS

Please refer to figure # 12

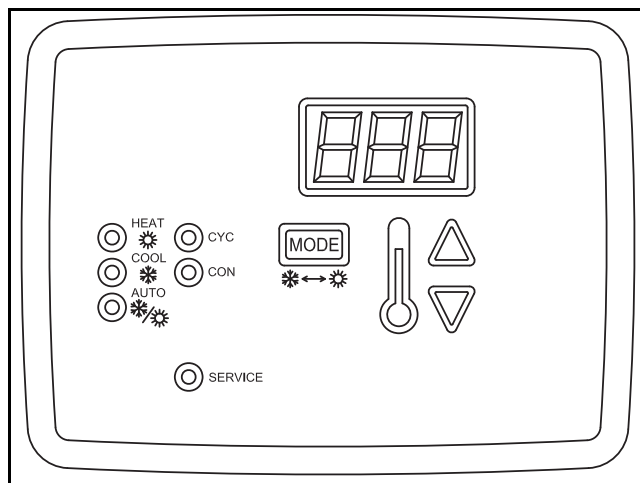

Figure # 12

User Interface

The following parameters are displayed on the screen:

- Control fluid temperature when in normal mode
- Settings within the configuration mode
- Individual operating mode temperature set points
- Fault display

UP Button:

- Press once to display the current set point temperature.
- After current set point temperature is displayed, pressing again will increment the set point 1 degree for every push. Pressing and holding the up button will increment the set point at a rate of 4 degrees per second.
- When pressed with the down arrow for 5-seconds, the control will display the current temperature scale (Fahrenheit or Celsius).
- Used to change the settings for: temperature scale, dead band, test mode, initial delay, compressor, pump, and malfunction settings.

DOWN Button:

- Press once to display the current set point temperature.
- After current set point temperature is displayed,

pressing again will decrement the set point 1 degree for every push. Pressing and holding the down button will decrement the set point at a rate of 4 degrees per second.

- When pressed with the up arrow for 5- seconds, the control will display the current temperature scale (Fahrenheit or Celsius).
- Used to change the settings for: temperature scale, dead band, test mode, initial delay, compressor, pump, and malfunction settings.

LED Indicators

Mode	Indication
HEAT	Red LED to indicate that the control is in the HEATING mode
COOL	Green LED to indicate that the control is in the COOLING mode
AUTO	Yellow LED to indicate that the control is in AUTO mode
COM	Red LED to indicate that pump(s) are selected for continuous operation
CYC	Red LED to indicate that pump(s) are selected for cycling operation
SERVICE	Red LED will turn steady on or blink to indicate that a pressure switch has opened

USER ADJUSTABLE SETTINGS CHART

Settings	Range	Default
TEMP SETTING	40-120° F Heating and Cooling	
DIFFERENTIAL	1-10°F	1°F
MODE	Heat, Cool, Auto, Off	Off
TEMP SCALE	F °, C °	F
PUMP MODE	Con (continuous), Cyc (cycle)	Von
DEAD BAND	1-6 ° F	3 ° F
AUTO CHANGE OVER	55-85 ° F	65 ° F
TEST MODE	De (delay), or Nd (No delay)	De
COMPRESSOR	Si (Single), Du (Dual)	Si

Settings	Range	Default
LEAD LAG	0-14 Days	0
MALFUNCTION	St (Steady), Pu (Pulsing)	St

SETTING UP THE CONTROLLER

On unit power up the LED display will show the software version, temperature differential setting with the ability for the user to change it for ten seconds then will display “OFF” and then finally will display the control temperature of the fluid being measured (entering fluid, leaving fluid, tank, etc.) The default setting of the differential is 1°F and can be adjusted from 1 – 10° F at start up. The differential setting is the differential between set point temperature and actual on/off temperature of the machine.

For example:

Cooling set point = 45° F

Differential = 1° F

The heat pump will cycle on in cooling at 46° F. If a two stage machine, stage 2 will come on at 48° F or 2° F degrees above set point and one degree differential. The unit will shut off at set point.

Heating set point = 120° F

Differential = 1° F

Stage one will come on at 119° F and stage 2 will come at 117° F. Both stages will remain running until set point is achieved. Stage 1 and stage 2 will cycle on and off according to the lead/lag programmed interval.

Whenever there is a demand for heating and cooling and during the first stage of operation the temperature isn't changing, then the control will activate the second stage after a three minute delay from the first stage activation. This logic will apply when the control is powered up, on a power interruption, when the mode function is set to OFF and then back to either HEAT or COOL and when switching from heating to cooling or vice versa in the auto changeover mode.

Heating and cooling set points are adjusted by selecting each mode on the key pad and then using the up-down arrows to select the set point. Thus, push cool mode button and use down arrow to 45° F. Push heat mode button and use up arrow to 120° F. The controller can be set to control heating only,

cooling only, or auto change modes. The mode button is pushed until the circular LED is lit next to the chosen control mode.

INITIAL CONFIGURATION

After power up and the steps above are completed the configuration default settings may be changed. Holding down the up and down arrow buttons simultaneously for 10 seconds will put the controller into the configuration mode. This mode will be exited if no other commands are given within a 10 second period.

Please review all the following steps and enter the values you want to set at each display field to avoid a time out period while configuring. This will also provide a record of the initial configuration settings.

First display field

Temperature scale OC or OF. This is selectable by using the up or down arrows. Once selected hit “mode” key to advance.

Scale: _____

Second display field

Pump operation: Continuous or cyclic. This is the load or source or both pumps output relay. This may be set to continuous pump or cyclic pump mode to cycle with the compressor by using the up or down arrows. Once selected hit “mode” key to advance.

Mode: _____

Third display field

Change over dead band setting: This is selectable from 1 to 6 degrees. This is adjustable from 1-6 degrees by using the up or down arrows. The dead band setting is only used in the auto change mode and defines the band where the unit will not operate. This helps eliminate the possibilities of the unit cycling from one mode to the other too quickly.

For example, on a heating \cooling residential application this could be set as wide as 6 degrees.

On a pool heater application this could be set as tight as 1 degree. Once selected hit the “mode” key to advance.

Value: _____

Fourth display field

Auto change over set point (S2). Adjustable from 55 to 85 degrees. Use up or down arrows to adjust. Hit the “mode” key to advance. The auto changeover sensor should be located in an area that will be indicative of whether the unit should be in the heating or cooling mode.

Value: _____

Fifth display field

Test mode setting, (DE) delay or (ND) no delay: This is utilized for testing the outputs of the controller by eliminating the time delays. Use the up or down arrows to select. The controller will automatically revert to DE after one cycle to insure safety timings are restored if installer \commissioner forgets to reset to DE. The ND setting could be selected at start-up to avoid prolonged waiting periods during commissioning.

Once selected hit the “mode” key to advance.

Setting: _____

Sixth display field

Compressor setting, (Si) single or (Du) dual. Use the up or down arrows to select. Hit the “mode” key to advance. This is only applicable on multi stage units. If set to Si on a dual circuit unit the second stage will not come on. Must be set to “DU” for all TW models.

Setting: _____

Seventh display field

Lead \ lag setting (dual compressor only). Set point is 0 to 14 days on lead compressor rotation sequence. Use up or down arrows to select. Hit “mode” key to advance. Must be set to “0” for all TW models.

Setting: _____

Eighth display field

Malfunction output setting, (Pu) pulsed or (St) standard constant on. This sets the malfunction output relay to mimic the fault blink code that is causing the safety lock-out. This can be used for remote monitoring and remote trouble shooting. Use the up or down arrows to select. Hit the “mode” key to advance.

Setting: _____



The controller is now configured and is fully operational.



A copy of this configuration sheet should be left with the home owner or building manager for their records of initial control settings.

UNIT CHECK-OUT SHEET

Customer Data

Customer Name _____ Date _____
 Address _____

 Phone _____ Unit Number _____

Unit Nameplate Data

Unit Make _____
 Model Number _____ Serial Number _____
 Refrigerant Charge (oz) _____
 Compressor: RLA _____ LRA _____
 Maximum Fuse Size (Amps) _____
 Maximum Circuit Ampacity _____

Operating Conditions

	Cooling Mode	Heating Mode
Load Side Entering/ Leaving Fluid Temp	_____ / _____	_____ / _____
Load Side Fluid Flow (gpm)	_____	_____
Source Side/ Leaving Fluid Temp	_____ / _____	_____ / _____
Source Side Fluid Flow (gpm)	_____	_____
Compressor Volts / Amps	_____ / _____	_____ / _____
Source Fluid Type	_____	_____
Fluid Flow (gpm)*	_____	_____
Fluid Side Pressure Drop*	_____	_____
Suction / Discharge Pressure (psig)*	_____ / _____	_____ / _____
Suction / Discharge Temp*	_____ / _____	_____ / _____
Suction Superheat*	_____	_____
Entering TXV / Cap Tube Temp*	_____	_____
Liquid Subcooling*	_____	_____

* Required for Troubleshooting ONLY

Bosch
 555 NW 65th Court
 Fort Lauderdale, FL 33309
 Phone: (866) 642-3198
 Fax: (800) 776-5529

TROUBLESHOOTING



Troubleshooting Information Solution column may reflect a possible fault that may be one of, or a combination of causes and solutions. Check each cause and adopt “process of elimination” and or verification of each before making any conclusion.

Unit Troubleshooting		
Problem	Possible Cause	Checks and Correction
ENTIRE UNIT DOES NOT RUN	Power Supply Off	Apply power, close disconnect
	Blown Fuse	Replace fuse or reset circuit breaker. Check for correct fuses
	Voltage Supply Low	If voltage is below minimum voltage specified on unit data plate, contact local power company.
UNIT OFF ON HIGH PRESSURE CONTROL	Discharge pressure too high	In “COOLING” mode: Lack of or inadequate water flow. Entering water temperature is too warm. Scaled or plugged condenser. In “HEATING” mode: Lack of or inadequate load side fluid flow.
	Refrigerant charge	The unit is overcharged with refrigerant. Reclaim refrigerant, evacuate and recharge with factor recommended charge.
	High pressure	Check for defective or improperly calibrated high pressure switch.
UNIT OFF ON LOW PRESSURE CONTROL	Suction pressure too low	In “COOLING” mode: Lack of or inadequate Source side fluid. flow. Entering water temperature is too cold. In “HEATING” mode: Lack of or inadequate water flow. Entering water temperature is too cold. Scaled or plugged condenser.
	Refrigerant charge	The unit is low on refrigerant. Check for refrigerant leak, repair, evacuate and recharge with factory recommended charge.
	Low pressure switch	Check for defective or improperly calibrated low pressure switch.
UNIT SHORT CYCLES	Unit oversized	Recalculate heating and or cooling loads.
	Thermostat	Thermostat installed near a supply air grill; relocate thermostat. Readjust heat anticipator.
	Wiring and controls	Check for defective or improperly calibrated low pressure switch.

Unit Troubleshooting		
Problem	Possible Cause	Checks and Correction
INSUFFICIENT COOLING OR HEATING	Unit undersized	Recalculate heating and or cooling loads. If excessive, possibly adding insulation and shading will rectify the problem
	fluid flow	Lack of adequate fluid flow.
	Refrigerant charge	Low on refrigerant charge causing inefficient operation
	Compressor	Check for defective compressor. If discharge is too low and suction pressure is too high, compressor is not pumping properly. Replace compressor.
	Reversing Valve	Defective reversing valve creating bypass of refrigerant from discharge of suction side of compressor. Replace reversing valve
	Operating pressures	Compare unit operation pressures to the pressure/temperature chart for the unit.
	TXV	Check TXV for possible restriction or defect. Replace if necessary.
	Moisture, noncondensables	The refrigerant system may be contaminated with moisture or noncondensables. Reclaim refrigerant, replace filter dryer, evacuate the refrigerant system, and recharge with factory recommended charge.

Comfort Alert Module - Flash Codes		
Status LED	Status LED Description	Status LED Troubleshooting Information Solution
YELLOW "ALERT" FLASH CODE 3	Short Cycling Compressor is running only briefly	<ol style="list-style-type: none"> 1. Thermostat demand signal is intermittent 2. Time delay relay or control board defective 3. If high pressure switch present go to Flash Code 2 information 4. If low pressure switch present go to Flash Code 1 information
YELLOW "ALERT" FLASH CODE 4	Locked Rotor	<ol style="list-style-type: none"> 1. Run capacitor has failed (may not be bad, verify) 2. Low line voltage (contact utility if voltage at disconnect is low) <ul style="list-style-type: none"> • Check wiring connections 3. Excessive liquid refrigerant in compressor 4. Compressor bearings are seized <ul style="list-style-type: none"> • Measure compressor oil level
YELLOW "ALERT" FLASH CODE 5	Open Circuit	<ol style="list-style-type: none"> 1. Outdoor unit power disconnect is open 2. Compressor circuit breaker or fuse(s) is open 3. Compressor contactor has failed open <ul style="list-style-type: none"> • Check compressor contactor wiring and connectors • Check for compressor contactor failure (burned, pitted or open) • Check wiring and connectors between supply and compressor • Check for low pilot voltage at compressor contactor coil 4. High pressure switch is open and requires manual reset 5. Open circuit in compressor supply wiring or connections 6. Unusually long compressor protector reset time due to extreme ambient temperature 7. Compressor windings are damaged <ul style="list-style-type: none"> • Check compressor motor winding resistance

Comfort Alert Module - Flash Codes

Status LED	Status LED Description	Status LED Troubleshooting Information Solution
YELLOW "ALERT" FLASH CODE 6	Open Start Circuit Current only in run circuit	<ol style="list-style-type: none"> 1. Run capacitor has failed (may not be bad, verify) 2. Open circuit in compressor start wiring or connections <ul style="list-style-type: none"> • Check wiring and connectors between supply and the compressor "S" terminal 3. Compressor start winding is damaged <ul style="list-style-type: none"> • Check compressor motor winding resistance
YELLOW "ALERT" FLASH CODE 7	Open Run Circuit Current only in start circuit	<ol style="list-style-type: none"> 1. Open circuit in compressor run wiring or connections <ul style="list-style-type: none"> • Check wiring and connectors between supply and the compressor "R" terminal 2. Compressor run winding is damaged <ul style="list-style-type: none"> • Check compressor motor winding resistance
YELLOW "ALERT" FLASH CODE 8	Welded Contactor Compressor always runs	<ol style="list-style-type: none"> 1. Compressor contactor has failed closed 2. Thermostat demand signal not connected to module
YELLOW "ALERT" FLASH CODE 9	Low Voltage Control circuit < 17VAC	<ol style="list-style-type: none"> 1. Control circuit transformer is overloaded 2. Low line voltage (contact utility if voltage at disconnect is low) <ul style="list-style-type: none"> • Check wiring connections Flash Code number corresponds to a number of LED flashes, followed by a pause and then repeated. TRIP and ALERT LEDs flashing at same time means control circuit voltage is too low for operation

HRP Troubleshooting

Problem	Possible Cause	Checks and Corrections
NO FLOW LOW FLOW	No Power	Check power supply
	On/Off Switch Position	Set switch to "ON" position
	Compressor Contactor	Engage heat pump contactor
	Broken or loose wires	Repair or tighten wires
	Air Lock	Purge air from piping system
	Stuck pump shaft/impeller	Remove pump cartridge and clean
	Defective pump	Replace pump
	Kinked or under sized water piping	Repair kink and check for proper line size
HIGH WATER TEMPERATURE	Water temp limit closed	Stuck limit switch Sensor not attached securely to line
LOW HEAT OUTPUT	Scaled or fouled heat exchanger	Clean heat exchanger

Unit Lockouts

Periodic lockouts almost always are caused by water flow problems. The lockout (shutdown) of the unit is a normal protective measure in the design of the equipment. If continual lockouts occur call a mechanic immediately and have them check for: water flow problems, water temperature problems. Use of the

pressure and temperature charts for the unit may be required to properly determine the cause

ELECTRICAL DATA TABLE

Models	Voltage Code	Rated Voltage	Voltage Min/ Max	Compressor				
				QTY	RLA	LRA	Min Circuit Amps	Max Fuse/ HACR
TW025	1	208-230/60/1	197/253	1	11.7	58.3	14.6	25
TW035	1	208-230/60/1	197/253	1	15.3	83.0	19.1	30
TW049	1	208-230/60/1	197/253	1	21.2	104.0	26.5	45
TW061	1	208-230/60/1	197/253	1	27.1	152.9	33.9	60
TW071	1	208-230/60/2	197/254	1	29.7	179.2	37.1	60
TW122	1	208-230/60/1	197/253	2	28.3	178.0	63.7	90

UPM Board LED Indications

Indication Color	Blinks	Description
GREEN	Solid	18-30 VAC Power is present
RED	1	High pressure lockout
RED	2	Low pressure lockout
RED	3	Freeze sensor lockout
RED	4	Condensate overflow
RED	5	Brownout
RED	6	Evaporator Freeze condition

WATER QUALITY TABLE.

Table 1: Water Quality			
POTENTIAL PROBLEM	Water Characteristic	Acceptable Value	
		Copper	Cupro-Nickel
	pH (Acidity/Alkalinity)	7-9	7-9
SCALING	Hardness (CaCO ₃ , MgCO ₃)	< 350 ppm	< 350 ppm
	Ryznar Stability Index	6.0 - 7.5	6.0 - 7.5
	Langelier Saturation Index	-0.5 - +0.5	-0.5 - +0.5
CORROSION	Hydrogen Sulfide (H ₂ S)	< 0.5 ppm *	10-50 ppm
	Sulfates	< 125 ppm	< 125 ppm
	Chlorine	< 0.5 ppm	< 0.5 ppm
	Chlorides	< 20 ppm	< 150 ppm
	Carbon Dioxide	< 50 ppm	< 50 ppm
	Ammonia	< 2 ppm	< 2 ppm
	Ammonia Chloride	< 0.5 ppm	< 0.5 ppm
	Ammonia Nitrate	< 0.5 ppm	< 0.5 ppm
	Ammonia Hydroxide	< 0.5 ppm	< 0.5 ppm
	Ammonia Sulfate	< 0.5 ppm	< 0.5 ppm
	Dissolved Solids	< 1,000 ppm	< 1,500 ppm
IRON FOULING	Iron (Fe ²⁺ Iron Bacteria Potential)	< 0.2 ppm	< 0.2 ppm
	Iron Oxide	< 1 ppm	< 1 ppm
EROSION	Suspended Solids	< 10 ppm, < 600 µm size **	< 10 ppm, < 600 µm size **
	Maximum Water Velocity	6 ft/sec	6 ft/sec
* No "rotten egg" smell present at < 0.5 ppm H ₂ S.			
** Equivalent to 30 mesh strainer			

WIRING DIAGRAMS

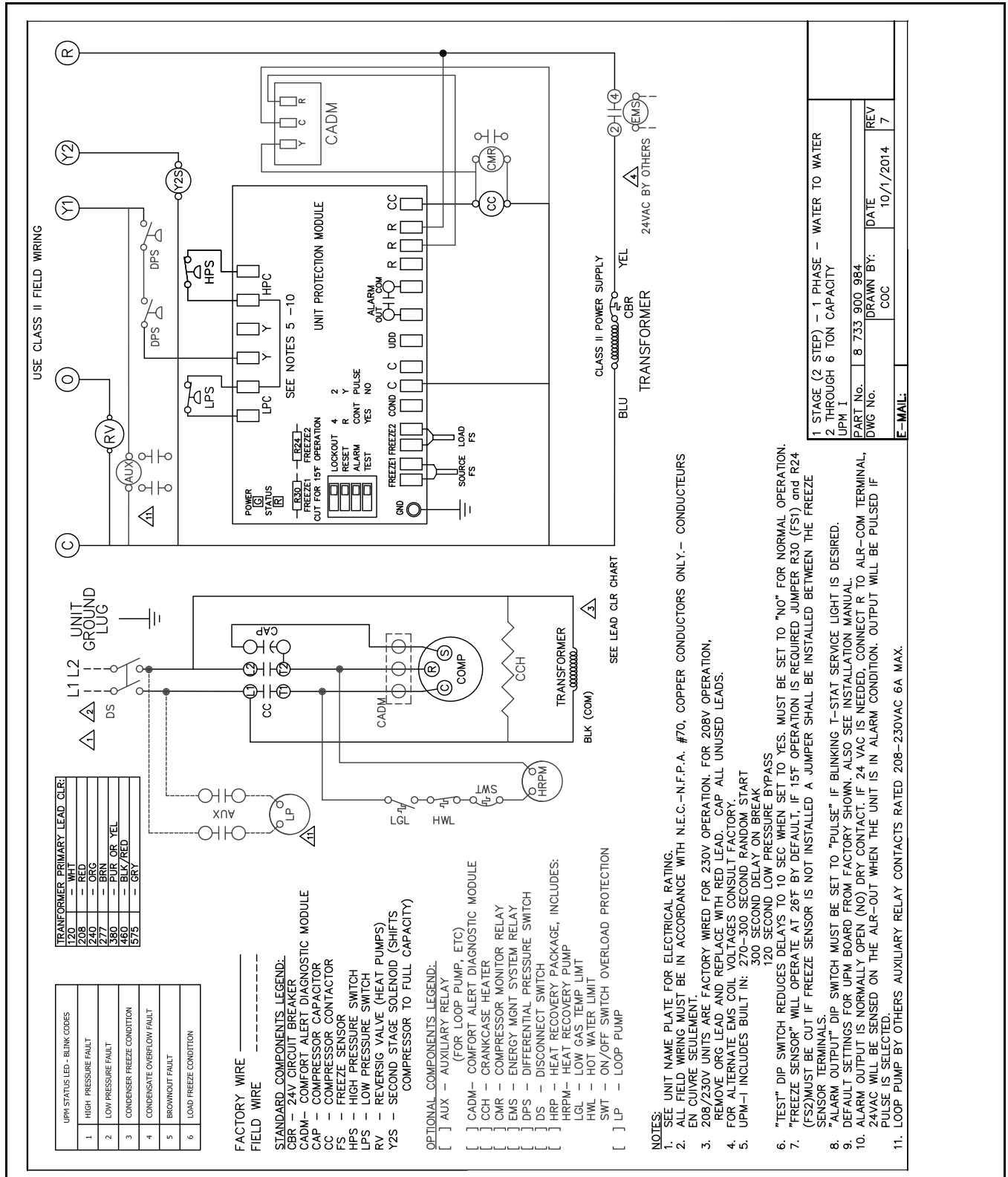

Figure # 13



FOR REFERENCE ONLY Actual unit wiring may vary from this example. Always refer to the wiring diagram attached to the unit.

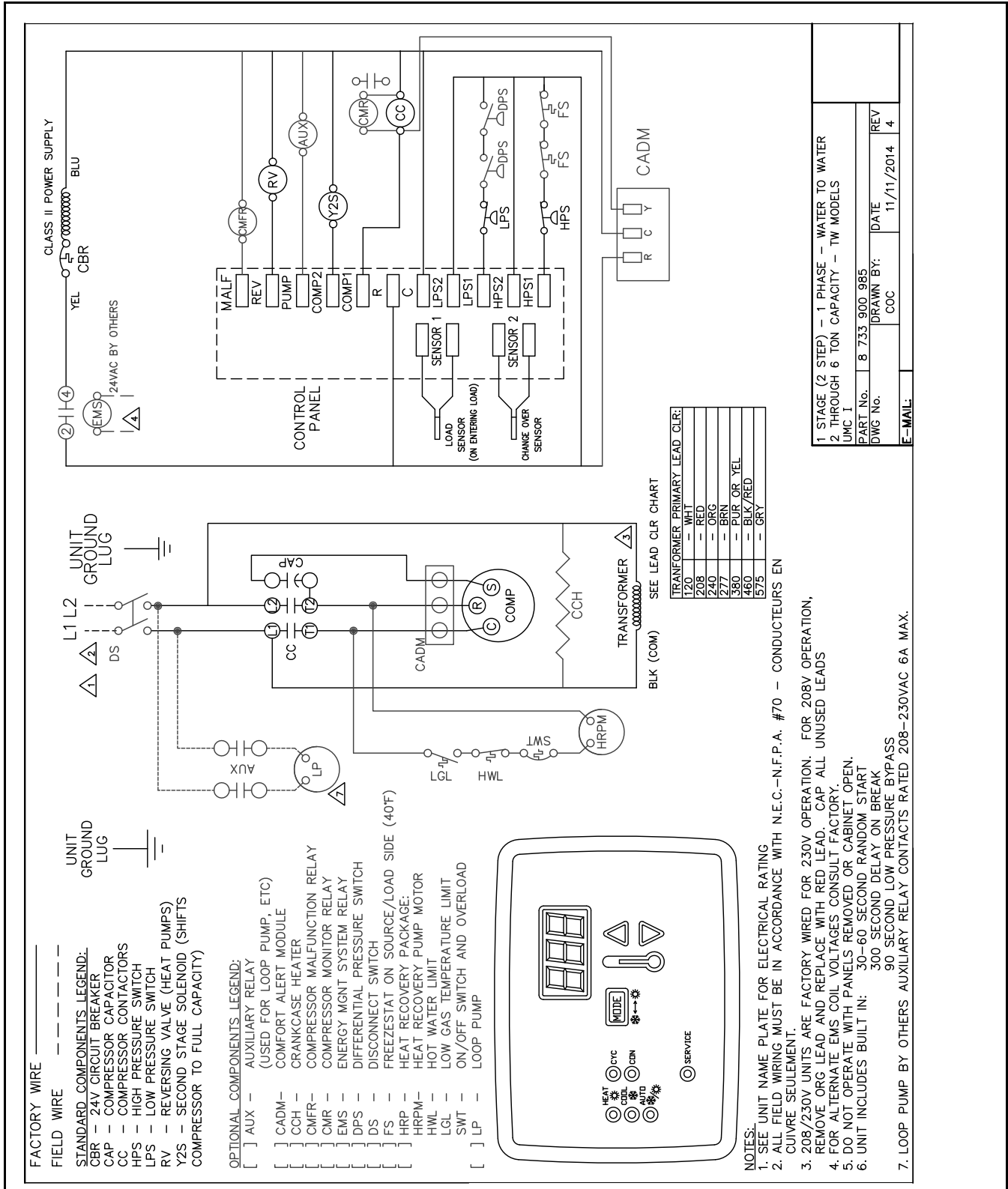

Figure # 14



FOR REFERENCE ONLY Actual unit wiring may vary from this example. Always refer to the wiring diagram attached to the unit.

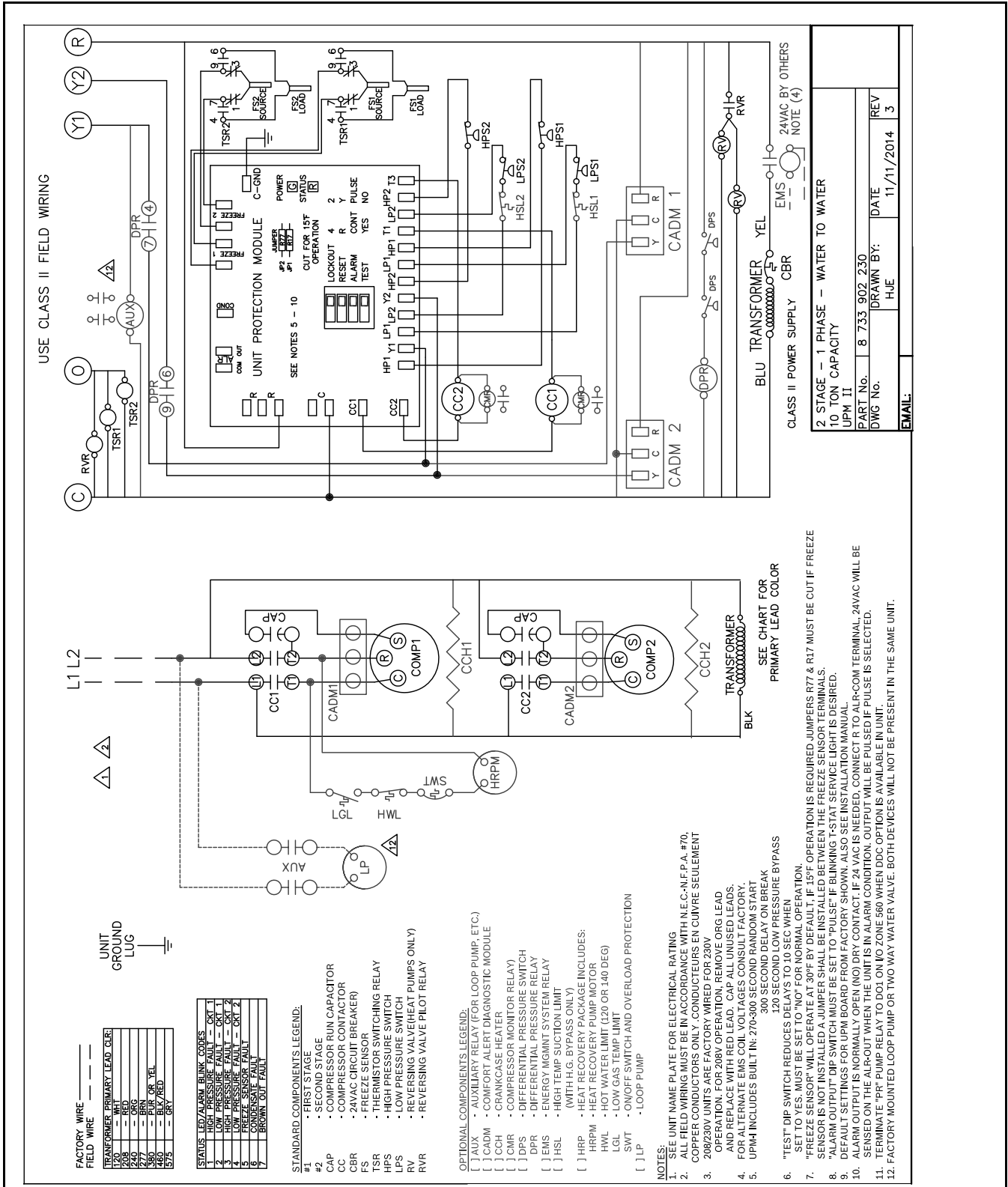
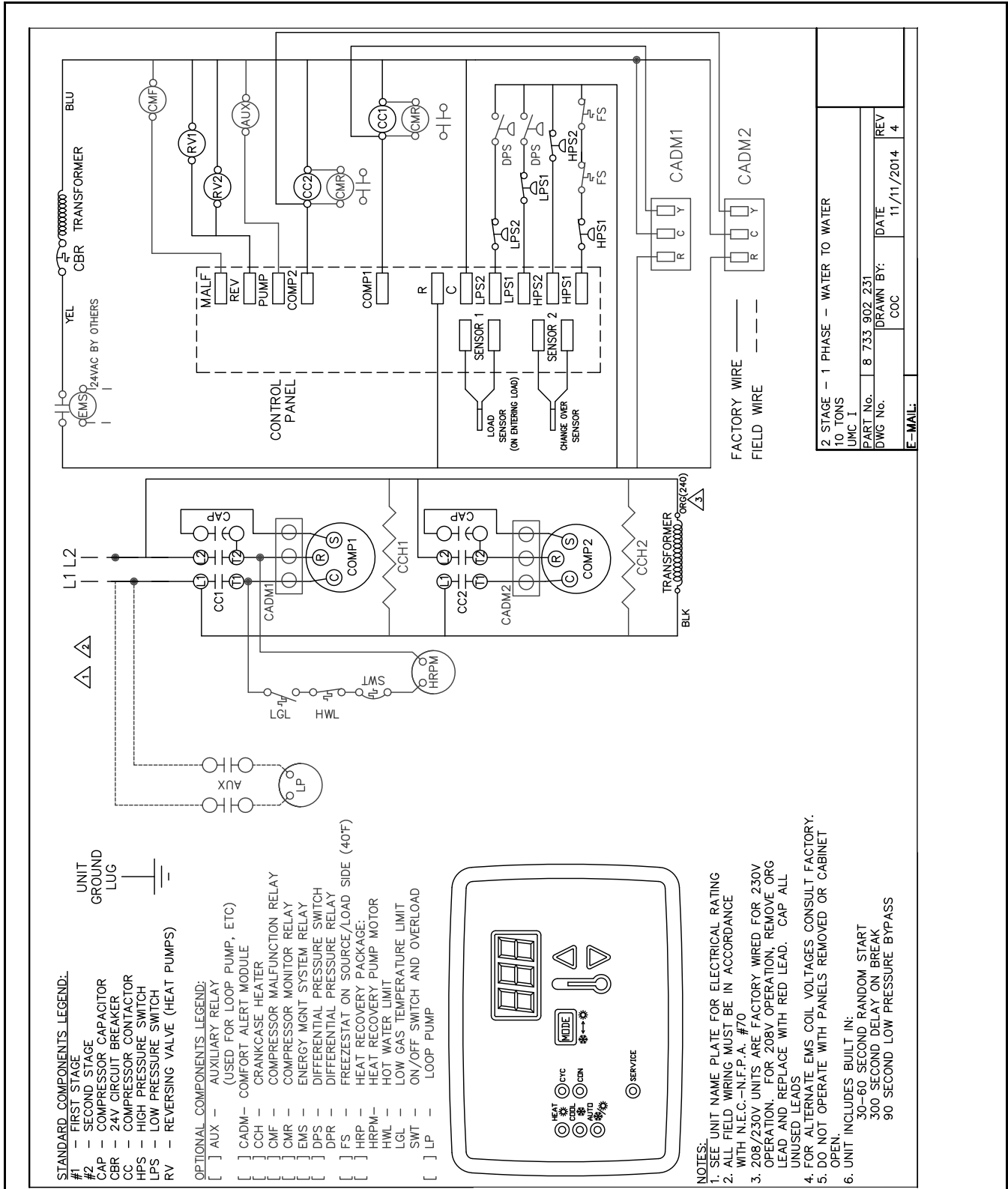

Figure # 15



FOR REFERENCE ONLY Actual unit wiring may vary from this example. Always refer to the wiring diagram attached to the unit.



i FOR REFERENCE ONLY Actual unit wiring may vary from this example. Always refer to the wiring diagram attached to the unit.

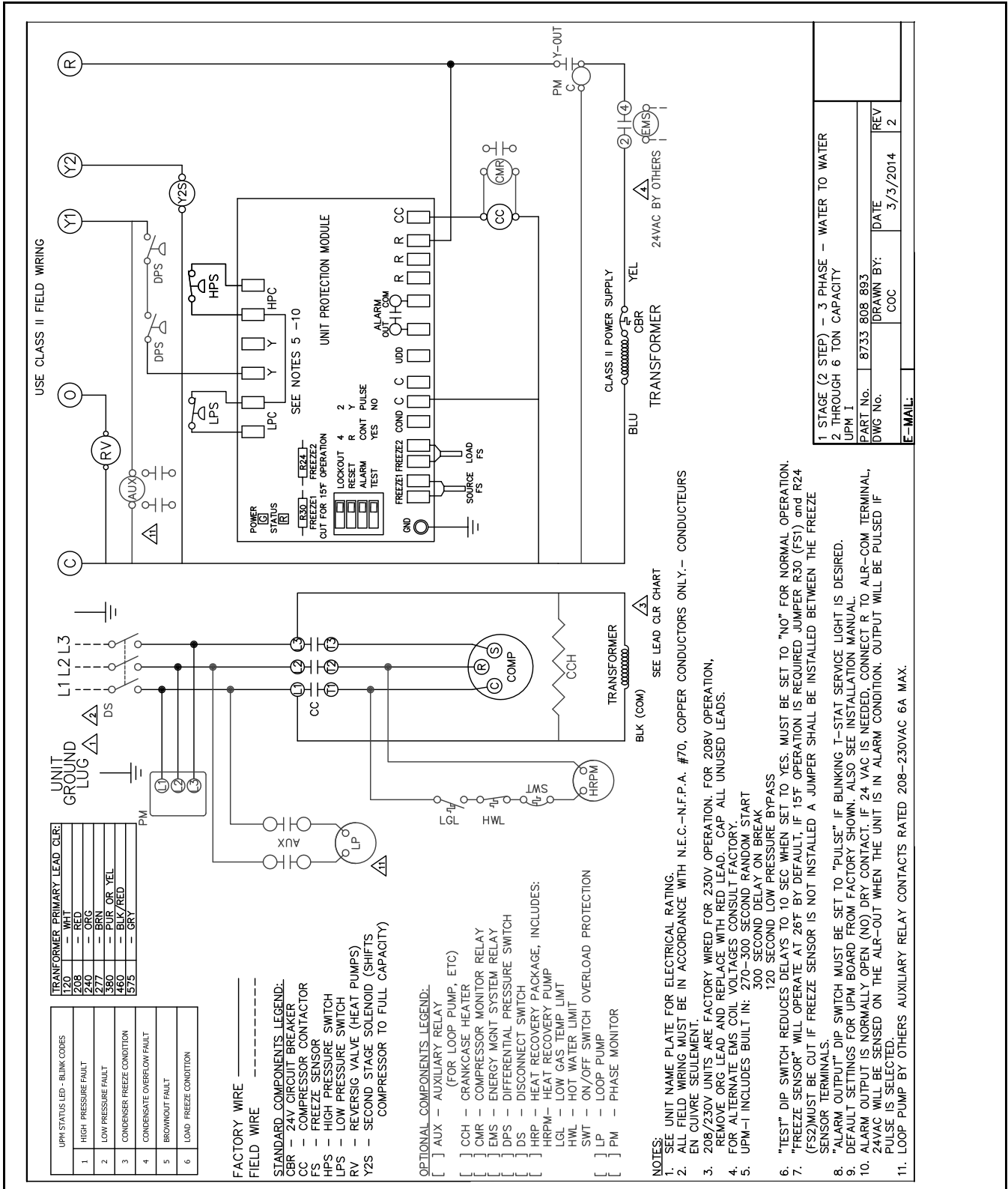

Figure # 17



FOR REFERENCE ONLY Actual unit wiring may vary from this example. Always refer to the wiring diagram attached to the unit.

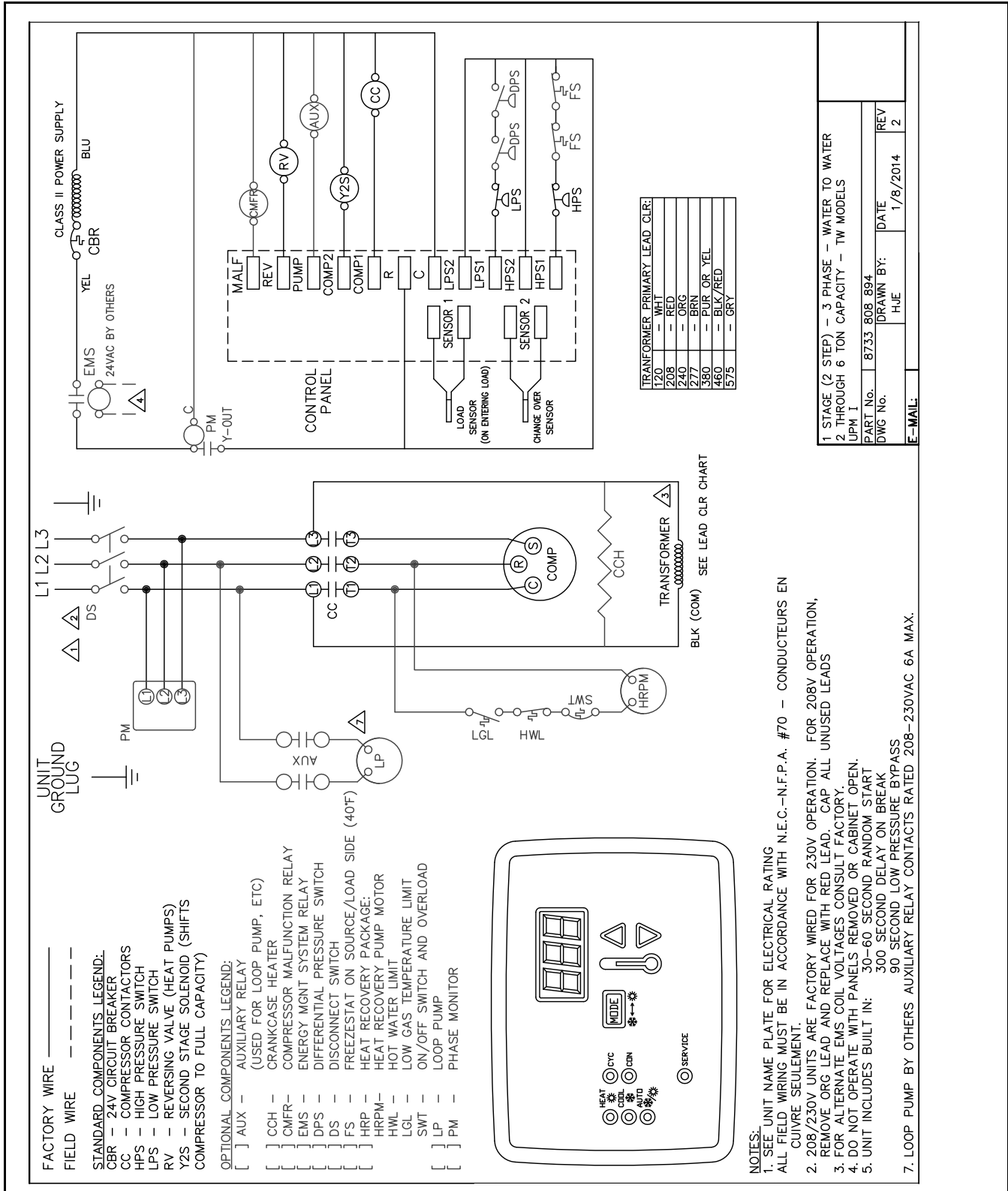

Figure # 18



FOR REFERENCE ONLY Actual unit wiring may vary from this example. Always refer to the wiring diagram attached to the unit.

DIMENSIONAL DRAWINGS

MODEL	A	B	C	D	E	F	G	H	J	K	L	M	N	P	Q	R	S	T	Water Conn.	HRP Conn.
	Height	Width	Depth																	
TW025	24.12	32.5	24	2.2	1.7	13.2	1.7	3.75	1.5	14.25	1.95	7.15	11	4.25	6.55	8.05	9.55	1.25	3/4 FPT	1/2 FPT
TW035	24.12	32.5	24	2.3	2.3	14.3	2.4	3.7	2.55	15.7	2.55	7.15	11	4.25	6.55	8.05	9.55	1.25	3/4 FPT	1/2 FPT
TW049	24.12	32.5	24	2.3	2.1	14.3	2.65	2.7	2.65	14.75	2.65	7.15	11	4.25	6.55	8.05	9.55	1.25	1 FPT	1/2 FPT
TW061	24.12	32.5	24	2.8	1.38	14.8	2.63	2.51	2	14.38	3.4	7.15	11	4.25	6.55	8.05	9.55	1.25	1 FPT	1/2 FPT
TW071	24.12	32.5	24	3	2.25	17.25	2.25	3.25	2.25	17	2.25	7.15	11	4.25	6.55	8.05	9.55	1.25	1 FPT	1/2 FPT

NOTES: All dimensions within +/- 0.125".
 Specifications subject to change without notice.

UNIT FRONT

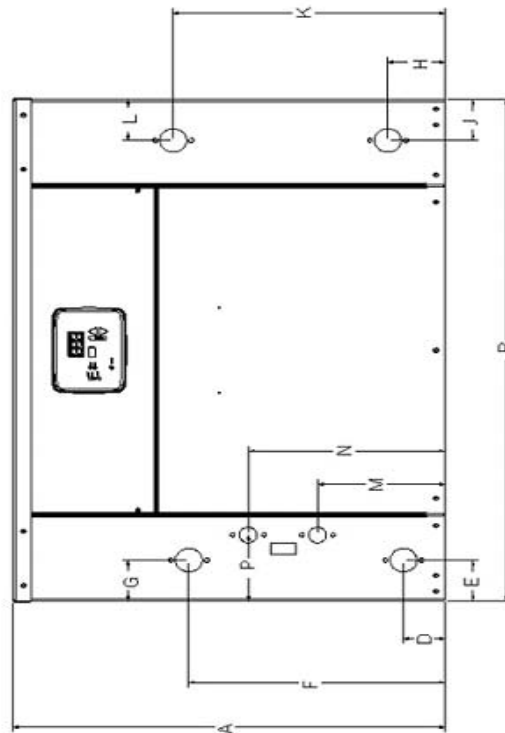

LEFT SIDE

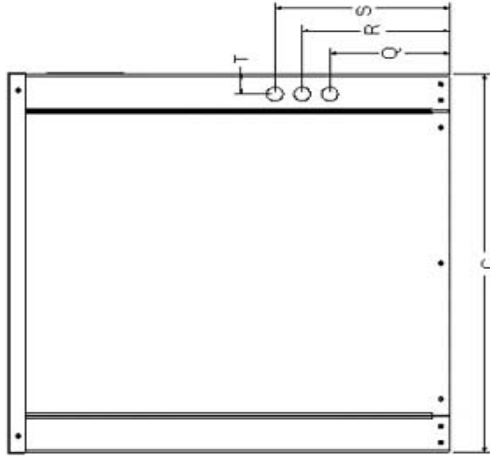

MODEL	A	B	C	D	E	F	G	H	J	K	L	M	Water Conn.
TW 122	37.5	27.62	7	8.38	9.25	33.5	20.75	13.5	17.5	3.5	46	28	1-1/4" FPT

NOTES: All dimensions within +/- 0.125".
Specifications subject to change without notice.

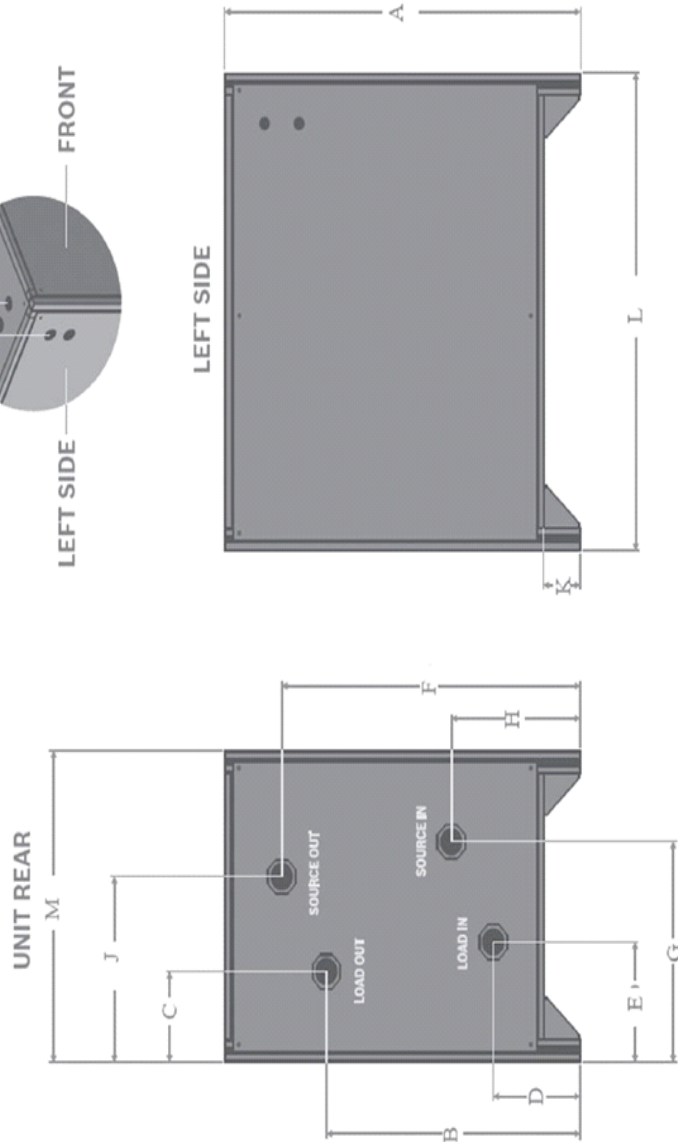
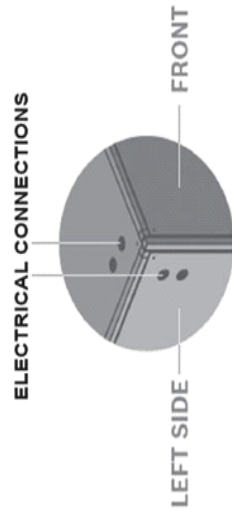

TERMINOLOGY

PSC - Permanent-split capacitor motor

EER - Energy Efficiency Ratio

COP - Coefficient of Performance. The COP provides a measure of performance for heat pumps that is analogous to thermal efficiency for power cycles.

ECM-Electronically Commutated Motor.

UPM-Unit Protection Module

WLHP - Water Loop Heat Pump

GLHP - Ground Loop Heat Pump

RLA - Running Load Amps

LRA - Locked Rotor Amps

FLA - Full Load Amps

NPA - Name Plate Amps

HP – Heat Pump

Suction Pressure - Pressure entering compressor

Discharge Pressure - Pressure leaving compressor

(R/A) - Return Air

Recovery - Means the collection and storage of fluorinated greenhouse gases from products, including containers, and equipment during maintenance or servicing or prior to the disposal of the products or equipment;

Recycling- Means the reuse of a recovered fluorinated greenhouse gas following a basic cleaning process;

Reclamation-Means the reprocessing of a recovered fluorinated greenhouse gas in order to match the equivalent performance of a virgin substance, taking into account its intended use;

Decommissioning- Means the final shut-down and removal from operation or usage of a product or piece of equipment containing fluorinated greenhouse gases;

Repair- Means the restoration of damaged or leaking products or equipment that contain, or whose functioning relies upon, fluorinated greenhouse gases,

involving a part containing or designed to contain such gases;

Conditioned space-Space within a building provided with heated or cooled air, or both (or surfaces); and, where required, with humidification or dehumidification means, to maintain conditions for an acceptable thermal environment.



BOSCH

Bosch Thermotechnology Corp.
555 N.W. 65th Court, Ft. Lauderdale, FL 33309
Phone: 866-642-3198 | Fax: 954-776-5529
www.boschheatingandcooling.com
Revised 02-16

